

WEBSTER PARISH SCHOOL BOARD
MINDEN, LOUISIANA

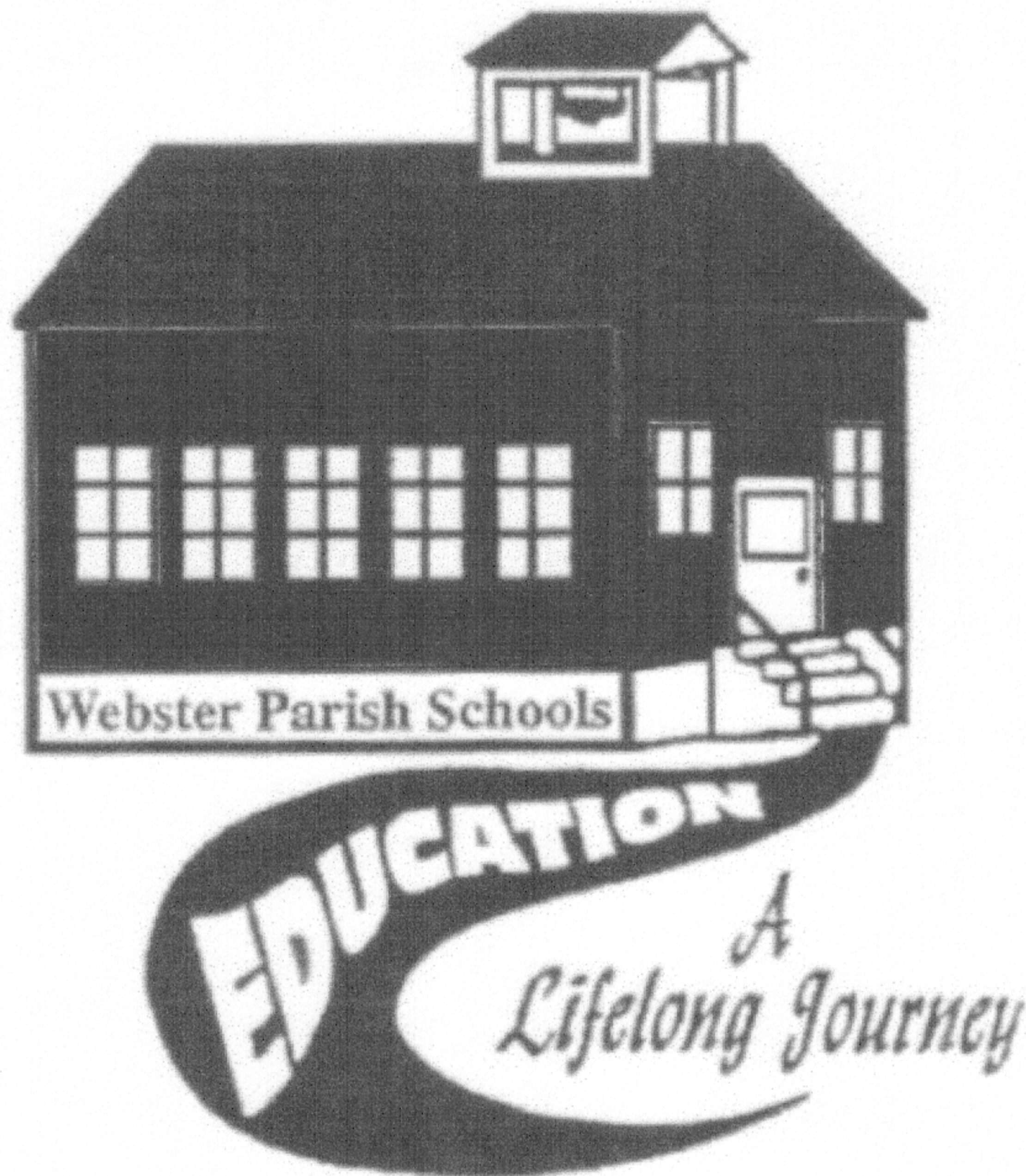

COMPREHENSIVE ANNUAL
FINANCIAL REPORT

FOR THE YEAR ENDED JUNE 30, 2003

(PREPARED PURSUANT TO GASB STATEMENT NO. 34
"NEW FINANCIAL REPORTING MODEL")

WEBSTER PARISH SCHOOL BOARD
Minden, Louisiana

COMPREHENSIVE ANNUAL FINANCIAL REPORT

FOR THE YEAR ENDED JUNE 30, 2003

**(Prepared pursuant to GASB Statement No. 34
"New Financial Reporting Model")**

WEBSTER PARISH SCHOOL BOARD
Minden, Louisiana

COMPREHENSIVE ANNUAL FINANCIAL REPORT
FOR THE YEAR ENDED JUNE 30, 2003

**(Prepared pursuant to GASB Statement No. 34
"New Financial Reporting Model")**

Willie K. Lynd, III
President

Wayne Williams, Jr.
Superintendent

Wayne King
Assistant Superintendent and
Supervisor of Personnel

Fred V. Evans
Director of Business & Finance

Prepared by the Department of Finance

**Webster Parish School Board
Comprehensive Annual Financial Report**

TABLE OF CONTENTS

		<u>Page</u>
INTRODUCTORY SECTION		
Letter of Transmittal		i-iv
GFOA Certificate		v
ASBO Certificate		vi
Organization Chart		vii
Elected Officials		viii
Selected Administrative Officials		ix
	<u>Statement</u>	
FINANCIAL SECTION		
INDEPENDENT AUDITORS' REPORT		1-2
REQUIRED SUPPLEMENTAL INFORMATION		3
Management's Discussion and Analysis (MD&A)		4-13
BASIC FINANCIAL STATEMENTS		
Government-wide Financial Statements (GWFS)		14
Statement of Net Assets	A	15
Statement of Activities	B	16
Fund Financial Statements (FFS)		17
Governmental Funds:		
Balance Sheet	C	18-19
Reconciliation of the Governmental Funds Balance Sheet to the Statement of Net Assets	D	21
Statement of Revenues, Expenditures, and Changes in Fund Balances	E	22-25
Reconciliation of the Governmental Funds Statement of Revenues, Expenditures, and Changes in Fund Balances to the Statement of Activities	F	26
Fiduciary Fund:		
Statement of Fiduciary Assets and Liabilities	G	27
Notes to the Basic Financial Statements		
Index		28
Notes		29-44
	<u>Exhibit</u>	
REQUIRED SUPPLEMENTAL INFORMATION		45-46
Budgetary Comparison Schedules		
General Fund	1-1	47
Title I	1-2	48
1996 Sales Tax	1-3	49
Notes to the Budgetary Comparison Schedules		50-51

**Webster Parish School Board
Comprehensive Annual Financial Report**

TABLE OF CONTENTS

	<u>Exhibit</u>	<u>Page</u>
FINANCIAL SECTION (Continued)		
OTHER SUPPLEMENTAL INFORMATION		52
Combining Non-Major Governmental Funds and Agency Funds		52
Combining Balance Sheet	2	53
Combining Statement of Revenues, Expenditures and Changes in Fund Balances - By Fund Type	3	54-55
Non-Major Special Revenue Funds		56-57
Combining Balance Sheet	4	58-60
Combining Statement of Revenues, Expenditures, and Changes in Fund Balances	5	62-67
Statements of Revenues, Expenditures, and Changes in Fund Balance - Budget (GAAP Basis) and Actual		
Other ESEA Funds	6-1	68
Special Education	6-2	69
Special Federal Funds	6-3	70
Building Maintenance Tax	6-4	71
School Food Service	6-5	72
Piney Hills Consortium	6-6	73
Technology Literacy Challenge	6-7	74
Education Excellence	6-8	75
Comprehensive School Reform	6-9	76
Springhill Lease	6-10	77
Shongaloo Lease	6-11	78
Minden Lease	6-12	79
Non-Major Debt Service Funds		81
Combining Balance Sheet	7	82-83
Combining Statement of Revenues, Expenditures, and Changes in Fund Balances	8	84
Nonmajor Capital Project Funds		87
Combining Balance Sheet	9	88-89
Combining Statement of Revenues, Expenditures and Changes in Fund Balances	10	90-91
Agency Funds		92
School Activities Agency Fund		
Statement of Changes in Assets and Liabilities	11	93
Schedule of Changes in Deposits Due Others	12	94
Capital Assets Used in the Operation of Governmental Funds		95
Schedule of Capital Assets - By Source	13	96
Schedule of Capital Assets - By Function	14	97
Schedule of Changes in Capital Assets - By Function	15	98
Schedule of Compensation Paid Board Members	16	99

**Webster Parish School Board
Comprehensive Annual Financial Report**

TABLE OF CONTENTS

	<u>Table</u>	<u>Page</u>
STATISTICAL SECTION		
Government-Wide Financial Statements		
Government-Wide Expenses by Function	1	101
Government-Wide Revenues	2	102
Fund Financial Statements		
General Expenditures by Function	3	103
General Revenues by Source	4	104
Property Tax Levies and Collections	5	105
Assessed and Estimated Actual Value of Taxable Property	6	106
Property Tax Rates and Tax Levies - All Direct and Overlapping Governments	7	107
Ratio of Net General Obligation Bonded Debt to Assessed Value and Net General Obligation Bonded Debt Per Capita	8	108
Statement of Direct, Overlapping, and Underlying General Obligation Bonded Debt	9	109
Computation of Legal Debt Margin	10	110
Ratio of Annual Debt Service Expenditures for General Bonded Debt to Total General Expenditures	11	111
Demographic Statistics	12	112
Property Value, Construction and Bank Deposits	13	113
Principal Taxpayers	14	114
Principal Employers	15	115
Attendance Data	16	116

INTRODUCTORY SECTION



WEBSTER PARISH SCHOOL BOARD

P.O. Box 520
1442 Sheppard Street
Minden, Louisiana 71058-0520

Telephone: (318) 377-7052
Fax: (318) 377-4114

Willie Lynd III
President

Johnnye Kennon
Vice-President

Wayne Williams, Jr.
Superintendent

Wayne King
Asst. Superintendent

Transmittal Letter

December 5, 2003

Mr. Willie K. Lynd, III, President
and Members of the Board
Webster Parish School Board
Minden, Louisiana

Dear Board Members:

The Comprehensive Annual Financial Report of the Webster Parish School Board (School Board) for the year ended June 30, 2003, is submitted herewith. This report has been prepared by the Finance Department personnel following the guidelines recommended by the Association of School Business Officials International and the Government Finance Officers Association of the United States of America and Canada.

A. Management Responsibility Responsibility for both the accuracy of the data, and the completeness and fairness of the presentation, including all disclosures, rests with the School Board. To the best of our knowledge and belief, the enclosed data is accurate in all material respects and is reported in a manner designed to present fairly the financial position and results of operations of the various funds of the School Board. All disclosures necessary to enable the reader to gain an understanding of the School Board's financial activities have been included.

B. Explanation of the CAFR The Comprehensive Annual Financial Report (CAFR) consists of three parts:

(1) The Introductory Section. This section includes a transmittal letter, information on financial reporting achievements, the School Board's organizational structure, recognition of the elected officials of the School Board and a list of selected administrative officials.

(2) The Financial Section. The financial section consists of Management's Discussion and Analysis, basic financial statements, required supplemental information, and combining non-major and individual fund statements and schedules. The basic financial statements present both an overview and a broad long-term perspective of the School Board as a whole in the government-wide financial statements. Fund financial statements provide the next level of detail. These statements tell how services were financed in the short-term as well as what remains for future spending. Fund statements also may give some insights into the School Board's overall financial health.

Combining statements are presented when a School Board has at least one nonmajor fund of a given fund category. Various statements are also used to demonstrate finance-related legal and contractual compliance, present other information deemed useful, and provide details of data summarized in the financial statements.

(3) The Statistical Section. Included in this section are a number of tables of unaudited data depicting the financial history, demographics and other miscellaneous information of the School Board for the past ten years.

The School Board is required to undergo an annual single audit in conformity with the provisions of the Single Audit Act Amendments of 1996 and U. S. Office of Management and Budget Circular No. A-133, Audits of State, Local Governments, and Non-Profit Organizations. Information related to this single audit includes the Schedule of Expenditures of Federal Awards, findings and recommendations, if applicable, and auditor's reports on the internal control and compliance with applicable laws and regulations. The single audit report is issued separately from this Comprehensive Annual Financial Report.

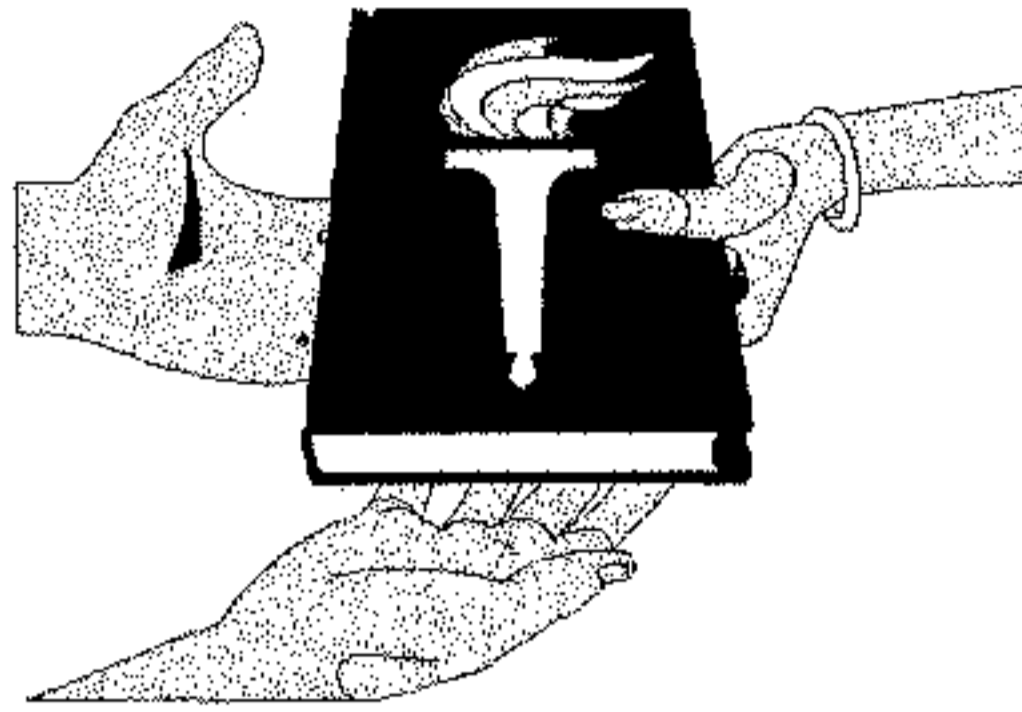

The School Board provides a full range of educational services appropriate to grade levels K through 12. These include providing instructional personnel, instructional materials, instructional facilities, food service facilities, administrative support, business services, systems operations, plant maintenance and bus transportation. These basic services are supplemented by a wide variety of offerings in the fine arts and athletics.

C. Definition of the Reporting Entity The report includes all entities or organizations that are required to be included in the School Board's reporting entity. The basic criteria for determining whether a governmental department, agency, institution, commission, public authority, or other governmental organization should be included in a governmental unit's reporting entity is financial accountability. Financial accountability includes the appointment of a voting majority of the organization's governing body and either the ability of the primary government to impose its will on the organization or if there is a financial benefit/burden relationship. In addition, an organization which is fiscally dependent on the primary government should be included in its reporting entity.

The financial statements present the Webster Parish School Board (the primary government). Based on the above criteria there are no component units included in the School Board's reporting entity.

D. Internal Control Management of the School Board is responsible for establishing and maintaining internal control designed to ensure that the assets of the School Board are protected from loss, theft or misuse and to ensure that adequate accounting data is compiled to allow for the preparation of financial statements in conformity with accounting principles generally accepted in the United States of America. Internal control is designed to provide reasonable, but not absolute, assurance that these objectives are met. The concept of reasonable assurance recognizes that: (1) the cost of a control should not exceed the benefits likely to be derived; and (2) the valuation of costs and benefits requires estimates and judgements by management.

We believe the School Board's internal accounting controls adequately safeguard assets and provide reasonable assurance of proper recording of financial transactions.

As a recipient of federal, state and local financial assistance, the School Board also is responsible for ensuring that adequate internal control is in place to ensure compliance with applicable laws and regulations related to those programs.

As a part of the School Board's single audit described earlier, tests are made to determine the adequacy of internal control, including that portion related to federal awards programs, as well as to determine that the School Board has complied with applicable laws and regulations. The results of the School Board's single audit for the fiscal year ended June 30, 2003, provided no instances of material weaknesses in the internal control structure or significant violations of applicable laws and regulations.

E. Budgetary Controls In addition, the School Board maintains budgetary controls to ensure compliance with legal provisions embodied in the annual appropriated budget approved by the School Board. Activities of the general fund and special revenue funds are included in the annual appropriated budget. The level of budgetary control (that is, the level at which expenditures cannot legally exceed the appropriated amount) is established by function by fund. School Board policy provides that expenditures within a fund may not exceed appropriations by more than five percent. Revisions to the budget require School Board approval.

F. Cash Management Cash temporarily idle during the year was invested in demand deposits and certificates of deposit. Deposits in financial institutions are collateralized by instruments issued by the United States Government or federal government agencies created by an act of congress or insured by the Federal Deposit Insurance Corporation. The School Board earned the following interest revenue for the year ended June 30, 2003:

General	\$188,832
1996 sales tax	48,725
Other governmental	<u>93,231</u>
Total	<u>\$330,788</u>

G. Risk Management The School Board carries commercial insurance to manage its risk of loss from property damage, theft and claims against employees. The School Board is self-insured for general liability.

H. Service Efforts and Accomplishments Each year our school system ranks in the top 10% of all school districts in the state for the percentage of total general fund expenditures spent on instruction. We are proud to say that 75.23% of total general fund expenditures (as defined by the Louisiana Department of Education) for the 2002-2003 school year was for instruction. Few school districts in the state ranked higher. The following chart illustrates the percentage spent on instruction and other expenditure functions for the 2002-2003 school year:

**General Fund Expenditures
For the Fiscal 2002-2003 Year**

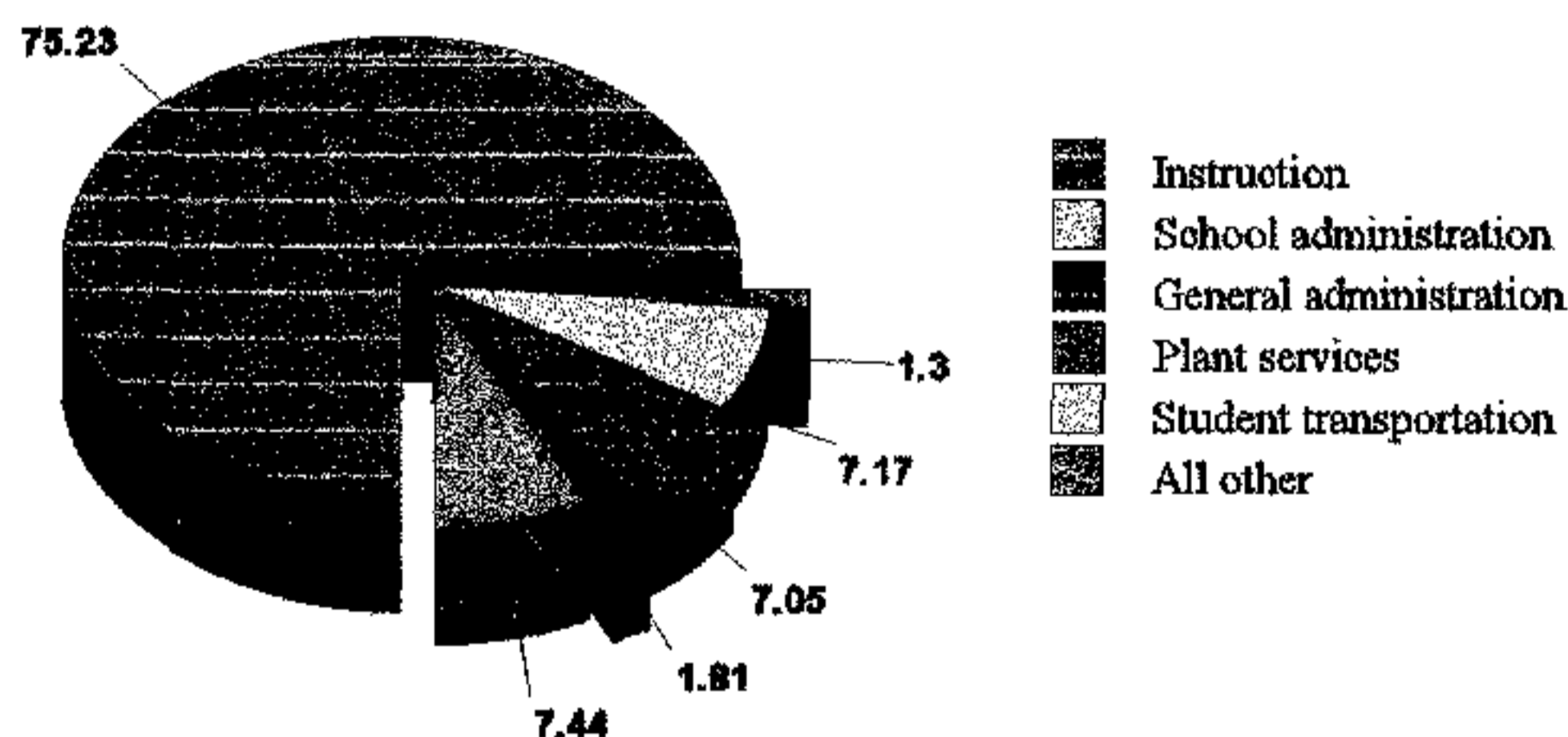

I. Independent Audits The report of our independent certified public accountants, Allen, Green & Williamson, LLP, follows as an integral component of this report. Their audit of the basic financial statements and accompanying combining and individual fund statements and schedules was performed in accordance with auditing standards generally accepted in the United States of America and, accordingly, included a review of the School Board's system of budgetary and accounting controls. The single audit report, as discussed earlier in this transmittal letter, is issued separately from this Comprehensive Annual Financial Report.

J. Awards The Government Finance Officers Association of the United States and Canada (GFOA) awarded a Certificate of Achievement for Excellence in Financial Reporting and the Association of School Business Officials International (ASBO) awarded a Certificate of Excellence in Financial Reporting to the School Board for its Comprehensive Annual Financial Report for the year ended June 30, 1998 and each year since. To be awarded these certificates, a government unit must publish an easily readable and efficiently organized Comprehensive Annual Financial Report, whose contents conform to program standards. Such reports must satisfy both accounting principles generally accepted in the United States of America and applicable legal requirements. These certificates are valid for a period of one year only.

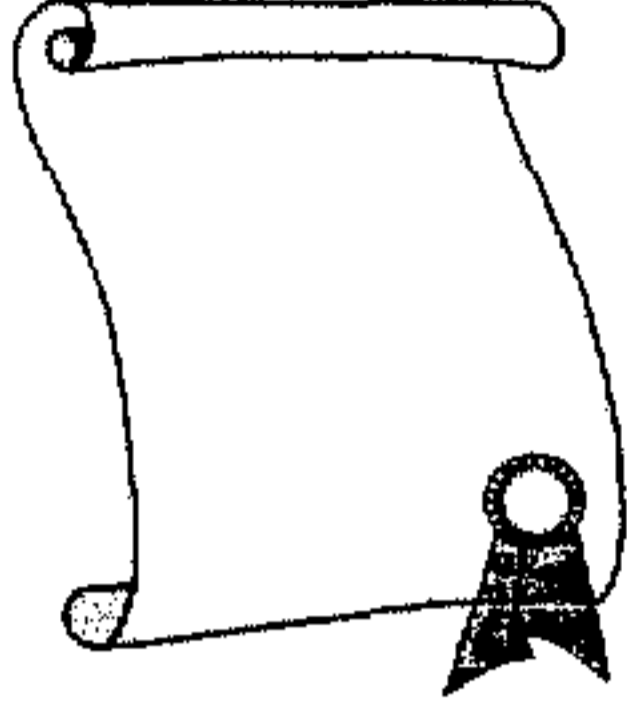

We believe our current report continues to conform to the certificate requirements, and we are submitting it to both GFOA and ASBO.

K. Acknowledgments The preparation of this report could not have been accomplished without the efficient and dedicated services of the entire staff of the Department of Finance. We want to express our appreciation to them for their assistance. We also thank the members of the School Board for their interest and support in planning and conducting the financial operations of the school system in a responsible and progressive manner.

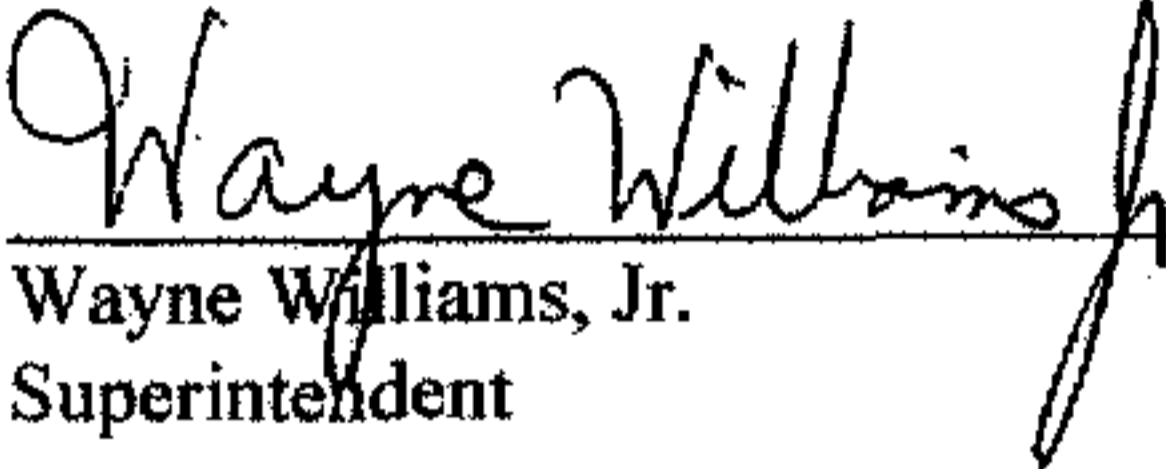
Wayne Williams, Jr.
Superintendent

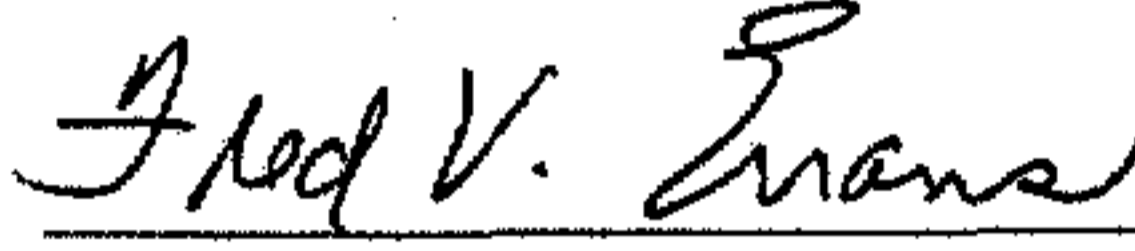
Fred V. Evans
Director of Business & Finance

Certificate of Achievement for Excellence in Financial Reporting

Presented to

Webster Parish School
Board, Louisiana

For its Comprehensive Annual
Financial Report
for the Fiscal Year Ended
June 30, 2002

A Certificate of Achievement for Excellence in Financial Reporting is presented by the Government Finance Officers Association of the United States and Canada to government units and public employee retirement systems whose comprehensive annual financial reports (CAFRs) achieve the highest standards in government accounting and financial reporting.



President

Executive Director

**ASSOCIATION OF SCHOOL BUSINESS OFFICIALS
INTERNATIONAL**



This Certificate of Excellence in Financial Reporting is presented to

WEBSTER PARISH SCHOOL BOARD

For its Comprehensive Annual Financial Report (CAFR)

For the Fiscal Year Ended June 30, 2002

Upon recommendation of the Association's Panel of Review which has judged the Report substantially conforms to principles and standards of ASBO's Certificate of Excellence Program



President

Executive Director

Webster Parish School Board

Organization Chart

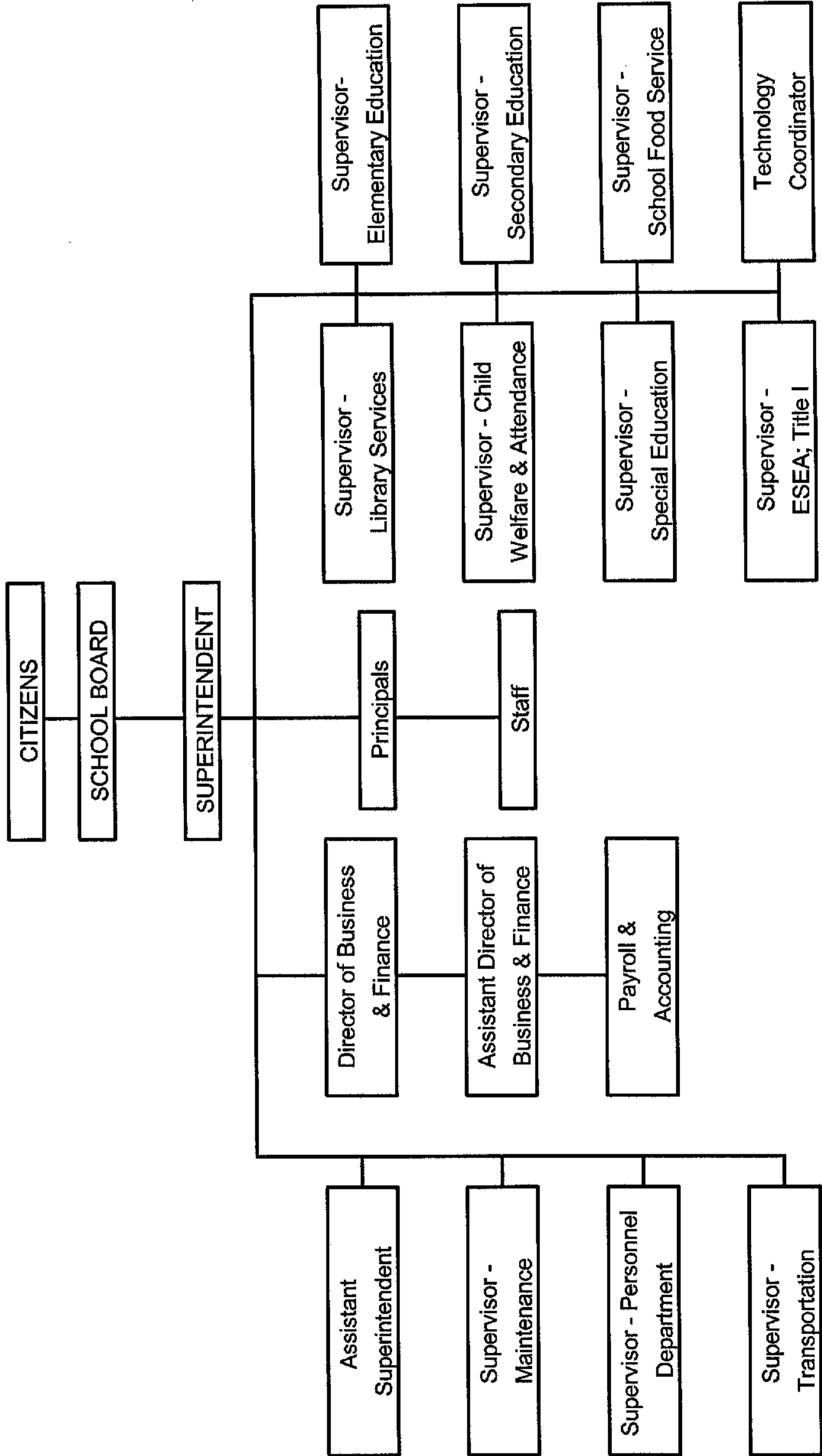
June 30, 2003



Webster Parish School Board

**Elected Officials
June 30, 2003**

<u>Board Member</u>	<u>District</u>
Mr. David Beaird	12
Mr. Ronnie Broughton	8
Mr. Mike Burns	4
Ms. Johnnye Kennon, Vice-President	10
Ms. Linda Kinsey	7
Mr. Willie K. Lynd, III, President	1
Ms. Frankie Mitchell	9
Mr. Harold Newsom	3
Mr. Malachi Ridgel	2
Mr. Greg Stinson	11
Ms. Sue Sullivan	5
Ms. Midge Woodard	6

Webster Parish School Board
Selected Administrative Officials
June 30, 2003

Wayne Williams, Jr.	Superintendent
Wayne King	Assistant Superintendent & Supervisor of Personnel
Jackie Sharp	Supervisor of Secondary Education
Diane Carmichael	Supervisor of Special Education
Judy Noles	Supervisor of Library Services
Kathy Miller	Supervisor of Elementary Education
James Smith	Supervisor - ESEA; Title I
Fred V. Evans	Director of Business & Finance
Betty Fowler	Supervisor of Child Nutrition Program
Willard "Buster" Flowers	Supervisor of Transportation
Donald Barton	Supervisor of Maintenance
West Moses	Supervisor of Child Welfare and Attendance
Linda Williams	Technology Coordinator

Webster Parish School Board

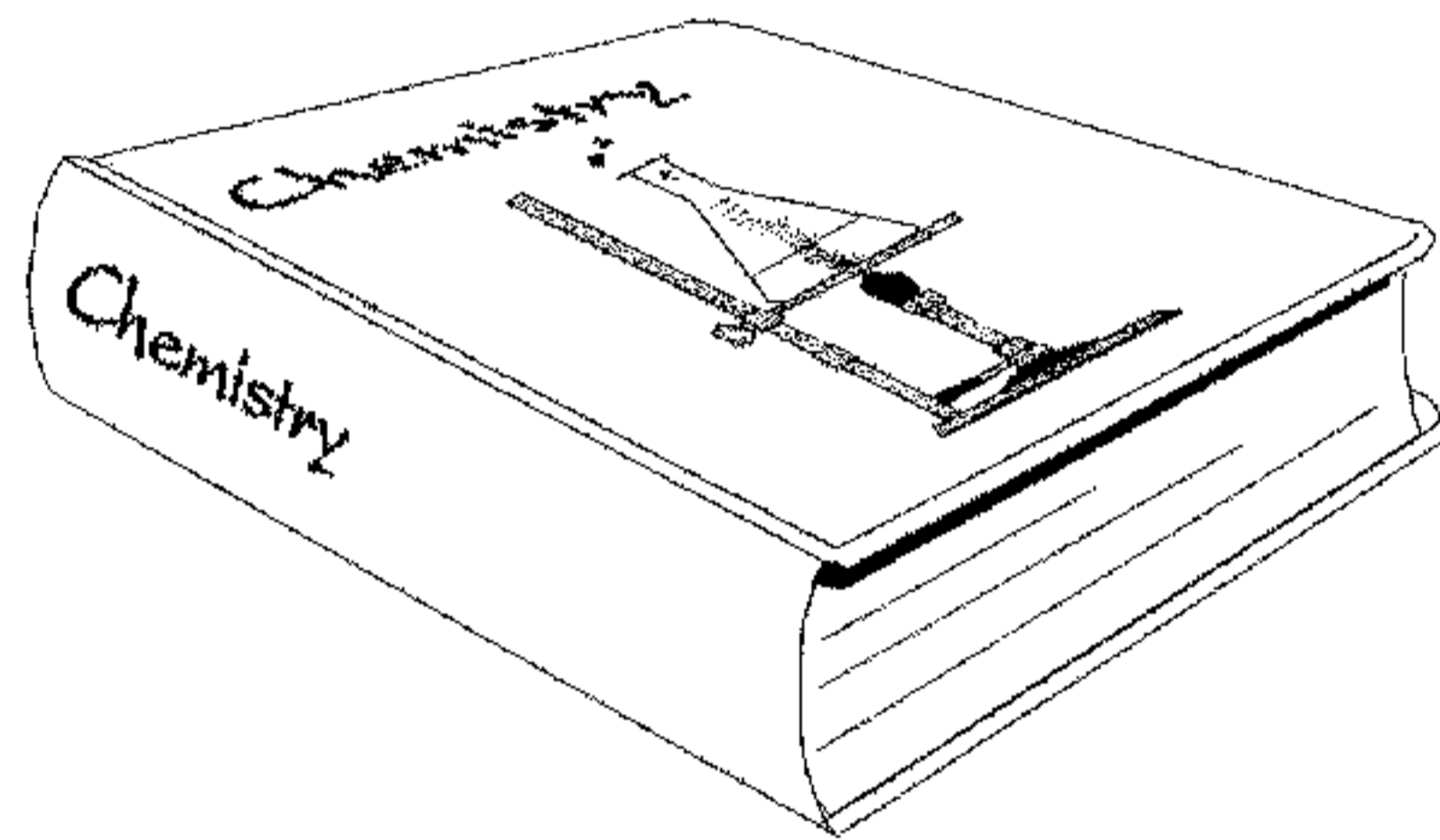

Webster Parish School Board

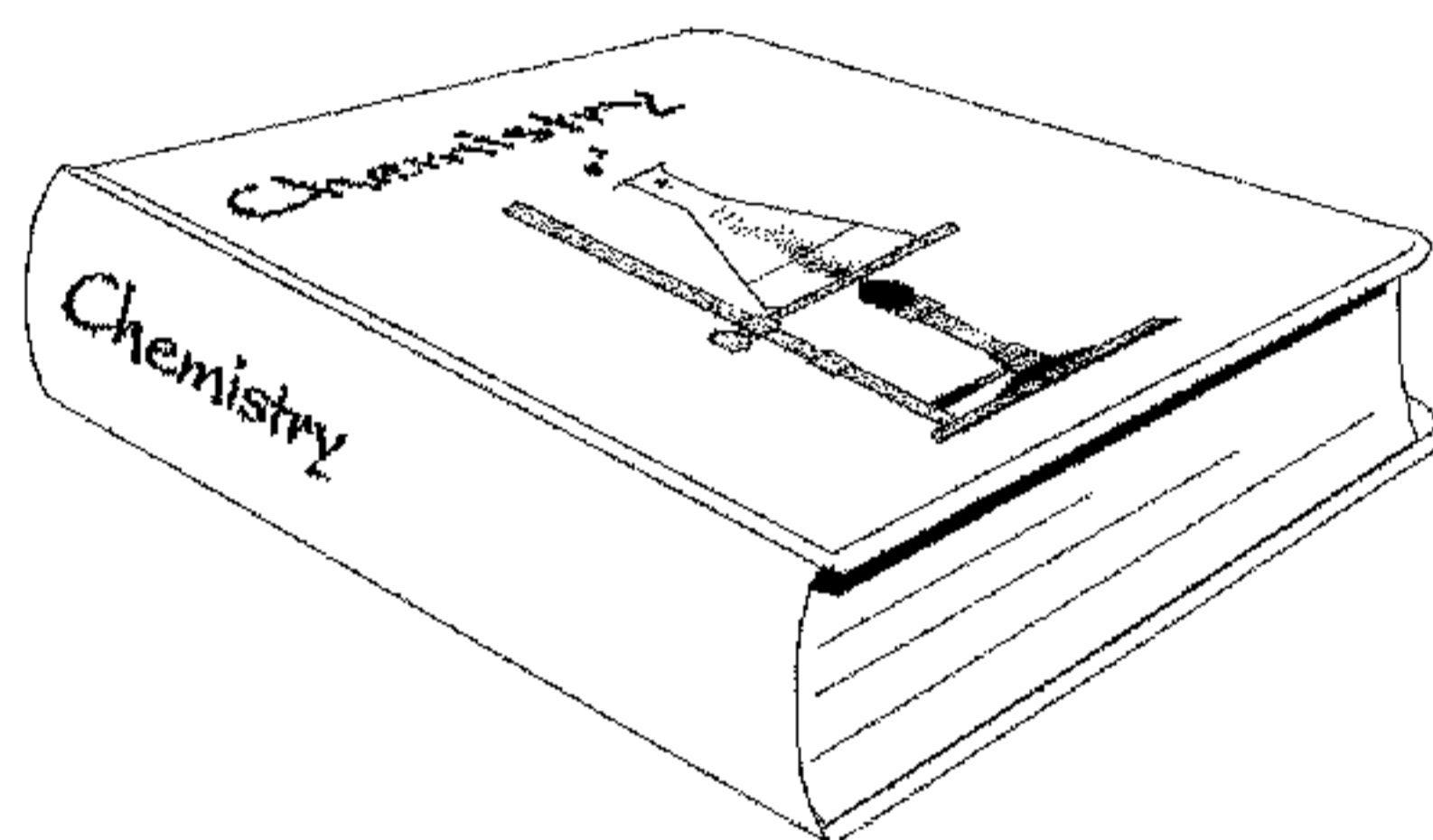

FINANCIAL SECTION

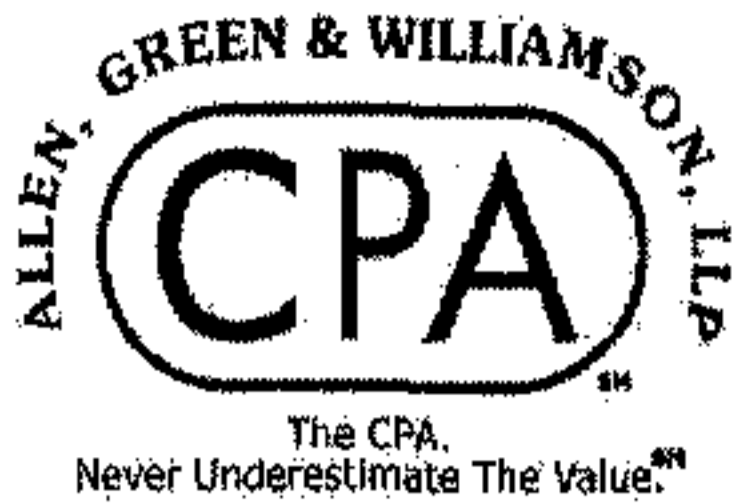

ALLEN, GREEN & WILLIAMSON, LLP

CERTIFIED PUBLIC ACCOUNTANTS

P. O. Box 6075

Monroe, LA 71211-6075

2414 Ferrand Street
Monroe, LA 71201

Phone: (318) 388-4422

Fax: (318) 388-4664

Toll-free: (888) 741-0205
www.allengreencpa.com

Tim Green, CPA

Margie Williamson, CPA

Ernest L. Allen, CPA
(Retired)
1963 - 2000

INDEPENDENT AUDITORS' REPORT

Board Members
Webster Parish School Board
Minden, Louisiana

Basic Financial Statements We have audited the accompanying *basic financial statements* of the governmental activities, the business-type activities, each major fund, and the aggregate remaining fund information of Webster Parish School Board as of and for the year ended June 30, 2003, as listed in the table of contents. These basic financial statements are the responsibility of the School Board's management. Our responsibility is to express an opinion on these basic financial statements based on our audit.

We conducted our audit in accordance with auditing standards generally accepted in the United States of America and the standards applicable to financial audits contained in Government Auditing Standards, issued by the Comptroller General of the United States of America. Those standards require that we plan and perform the audit to obtain reasonable assurance about whether the financial statements are free of material misstatement. An audit includes examining, on a test basis, evidence supporting the amounts and disclosures in the financial statements. An audit also includes assessing the accounting principles used and significant estimates made by management, as well as evaluating the overall financial statement presentation. We believe that our audit provides a reasonable basis for our opinion.

In our opinion, the *basic financial statements* referred to above present fairly, in all material respects, the respective financial position of governmental activities, each major fund and the aggregate remaining fund information of the School Board as of June 30, 2003, and the changes in financial position thereof for the year then ended in conformity with accounting principles generally accepted in the United States of America.

In accordance with Government Auditing Standards, we have also issued under separate cover, our report dated December 5, 2003, on our consideration of the School Board's internal control over financial reporting and on our tests of its compliance with certain provisions of laws, regulations, contracts and grants. That report is an integral part of an audit performed in accordance with Government Auditing Standards and should be read in conjunction with this report in considering the results of our audit.

Required Supplemental Information The Management's Discussion and Analysis and the Budgetary Comparison Schedules as listed in the table of contents, are not a required part of the *basic financial statements* but is supplemental information required by the Governmental Accounting Standards Board. We have applied certain limited procedures, which consisted principally of inquiries of management regarding the methods of measurement and presentation of the supplemental information. However, we did not audit the information and express no opinion on it.

Supplemental Information Our audit was performed for the purpose of forming an opinion on the *basic financial statements* that collectively comprise the School Board's *basic financial statements*. The accompanying information identified in the table of contents as supplemental information is presented for purposes of additional analysis and is not a required part of the *basic financial statements*. Such information has been subjected to the auditing procedures applied in the audit of the *basic financial statements* and, in our opinion, is fairly stated, in all material respects, in relation to the *basic financial statements* taken as a whole.

Other Information The information identified in the table of contents as the Introductory and Statistical Sections are presented for purposes of additional analysis and is not a required part of the *basic financial statements* of the School Board. Such information has not been subjected to the auditing procedures applied in the audit of the *basic financial statements* and, accordingly, we express no opinion on it.

Allen, Green + Williamson, LLP

ALLEN, GREEN & WILLIAMSON, LLP
Monroe, Louisiana

December 5, 2003

REQUIRED SUPPLEMENTAL INFORMATION

**MANAGEMENT'S DISCUSSION
AND ANALYSIS (MD&A)**

Webster Parish School Board

Management's Discussion and Analysis (MD&A) June 30, 2003

The discussion and analysis of Webster Parish School Board's financial performance provides an overall review of the School Board's financial activities for the fiscal year ended June 30, 2003. The intent of this discussion and analysis is to look at the School Board's financial performance as a whole; readers should also review the transmittal letter, notes to the basic financial statements and financial statements to enhance their understanding of the School Board's financial performance.

The MD&A is an element of the new reporting model adopted by the Governmental Accounting Standards Board (GASB) in their Statement No. 34 Basic Financial Statements - and Management's Discussion and Analysis - for State and Local Governments issued June 1999.

The Webster Parish School Board is located in the northwest corner of the state and is a part of the economic "hub" for this region. Located in the middle of the population center of North America, 40 million people live within a 500-mile radius of Webster Parish. Major markets such as Dallas/Fort Worth, New Orleans, Little Rock, Memphis, and Jackson can be reached in little more than a half day's drive or less. The accessibility to several major thoroughfares such as Interstate 20 and Interstate 49 has contributed to numerous decisions to locate in Webster Parish.

A diversified economic base is reflective of the many natural resources of the area such as oil and natural gas production, forestry, agriculture, paper products and silica mining. A broad variety of manufacturing includes production of portable communication buildings, dump truck trailers, metal fabrication, fishing tackle, corrugated boxes, industrial air louvers and dampers, and farm machinery. The South Webster Industrial District Park is 320 acres of improved land, offering all utilities and on-site rail. The Shreveport Regional Airport and Port of Shreveport-Bossier are each just 40 minutes west of the industrial park.

From primary education to advanced training, numerous education and training opportunities abound for the people of Webster Parish. The public school system includes 8 elementary, 2 middle, 10 high schools, and 2 alternative schools. Northwest Louisiana Technical College offers skill training and upgrading, and works closely with area business and industry to provide industry-specific training. Advanced education is easily attained through the nearby colleges and universities. Louisiana Tech University, Grambling State University, Bossier Parish Community College, Louisiana State University-Shreveport, Southern University-Shreveport/Bossier and Centenary College are less than an hour drive away.

Webster Parish School Board

Management's Discussion and Analysis (MD&A)
June 30, 2003

FINANCIAL HIGHLIGHTS Our financial statements provide these insights into the results of this year's operations:

- ◆ *Total revenues increased \$2.1 million due mainly to an increase in Minimum Foundation Program (MFP) of \$1.5 million. The MFP increase is due to increases from the funding formula and a repayment of a one-time salary adjustment. The federal funding increase was due to increases in technology, schools and roads, and Title II funds. The federal funding increase is offset by an equal increase in costs as these programs are all cost-reimbursement programs.*
- ◆ *The total cost of the School Board's programs for the fiscal year was \$52.7 million. Federal and state operating grants paid for \$8.5 million, user charges paid for \$0.8 million, state MFP funding paid for \$28.2 million, \$13.4 million was paid by Webster Parish taxpayers through ad valorem and sales tax, \$1.1 million was paid through other local sources, and the remainder of \$0.7 million was taken from fund balance.*
- ◆ *Major capital outlays for the year included purchases of computers and five buses.*

Total expenditures increased due to an increase in salaries and benefits.

FUND FINANCIAL STATEMENTS The fund balances of all governmental funds decreased \$3 million. This decrease is due to capital outlay of \$3.1 million at Cotton Valley. The fund balance in the general fund remained stable. The 96 sales tax fund reported an increase in fund balance of \$0.4 million. Sales tax revenue and interest earnings decreased \$0.1 million. Transfers to the general fund for salary supplements to certified personnel and support personnel accounted for a \$0.9 million decrease in fund balance.

Total revenues for all governmental funds for the current year was \$52 million, an increase of \$2 million from the prior year. Total expenditures for all governmental funds for the current year increased \$2 million to \$52.7 million.

GOVERNMENT-WIDE FINANCIAL STATEMENTS Most of the School Board's taxes and MFP funds were used to support the net cost (after deducting restricted grants and fees charged to users) of these four areas: instruction \$27.1 million, school administration \$2.8 million, plant services \$3.7 million, and student transportation \$2.5 million.

The School Board is mandated by state law to adopt its budget by September 15 of each year. This original budget reflects only guaranteed revenues and necessary expenditures since the major source of revenue, MFP, is based on the October 1 student count.

Webster Parish School Board

Management's Discussion and Analysis (MD&A)
June 30, 2003

USING THIS COMPREHENSIVE ANNUAL FINANCIAL REPORT (CAFR)

This annual report consists of a series of financial statements and notes to those statements. These statements are organized so that the reader can understand Webster Parish School Board as an entire operating entity. The statements then proceed to provide an increasingly detailed look at specific financial activities.

The Statement of Net Assets and the Statement of Activities provide information about the activities of the School Board as a whole, presenting both an aggregate view of the School Board's finances and a longer-term view of those finances. Fund financial statements provide the next level of detail. These statements tell how services were financed in the short-term as well as what remains for future spending. Fund statements also may give some insights into the School Board's overall financial health. Fund financial statements report the School Board's operations in more detail than the government-wide financial statements by providing information about the School Board's most significant funds – such as the School Board's General Fund, Title I, and 1996 sales tax. The remaining statement – the Statement of Fiduciary Net Assets presents financial information about activities for which the School Board acts solely as an agent for the benefit of students and parents.

<p>Comprehensive Annual Financial Report</p>
<p><u>Introductory Section</u> Transmittal Letter Organizational Chart Elected Officials and Selected Administrative Officers</p>
<p><u>Financial Section</u> (Details outlined in the next chart)</p>
<p><u>Statistical Section</u> Ten Years of Historical Financial Operating Data Ten Years of Property Tax Rates, Tax Levies and Collections Bonded Debt Information (including Bonded Debt Per Capita and Computation of Legal Debt Margin) Property Values, Construction and Bank Deposits Principal Employers and Ad Valorem Taxpayers Demographics and Attendance Data</p>

Webster Parish School Board

**Management's Discussion and Analysis (MD&A)
June 30, 2003**

Financial Section

Required Supplemental Information

Management's Discussion & Analysis (MD&A)

Basic Financial Statements

**Government-wide
Financial Statements**



**Fund
Financial Statements**

Notes to the Basic Financial Statements

Required Supplemental Information

Budgetary Information for Major Funds

Other Supplemental Information

**Nonmajor Funds Combining Statements & Budgetary Information
Agency Funds Statements/Schedules
Capital Assets Used in the Operation of Governmental Funds
Schedule of Compensation Paid Board Members**

Our auditor has provided assurance in the independent auditors' report, located immediately preceding this Management's Discussion and Analysis, that the Basic Financial Statements are fairly stated. The auditor has also provided varying degrees of assurance regarding the Required Supplemental Information and the Supplemental Information identified above. A user of this report should read the independent auditors' report carefully to ascertain the level of assurance being provided for each of the other parts in the Financial Section.

The School Board assumes full responsibility for the accuracy of the Introductory and Statistical Sections as they were prepared without the association of the independent auditors.

Webster Parish School Board

Management's Discussion and Analysis (MD&A)

June 30, 2003

REPORTING THE SCHOOL BOARD AS A WHOLE

The Statement of Net Assets and the Statement of Activities Our analysis of the School Board as a whole begins with the government-wide financial statements. One of the most important questions asked about the School Board is, "Is the School Board as a whole better off or worse off financially as a result of the year's activities?" The Statement of Net Assets and the Statement of Activities, which appear first in the School Board's financial statements, report information on the School Board as a whole and its activities in a way that helps you answer this question. We prepare these statements to include *all* assets and liabilities, using the *accrual basis of accounting*, which is similar to the accounting used by most private-sector companies. All of the current year's revenues and expenses are taken into account regardless of when cash is received or paid.

These two statements report the School Board's *net assets* – the difference between assets and liabilities, as reported in the Statement of Net Assets – as one way to measure the School Board's financial health, or *financial position*. Over time, *increases or decreases* in the School Board's net assets – as reported in the Statement of Activities – are one indicator of whether its *financial health* is improving or deteriorating. The relationship between revenues and expenses is the School Board's *operating results*. However, the School Board's goal is to provide services to our students, not to generate profits as commercial entities do. One must consider many other nonfinancial factors, such as the quality of the education provided and the safety of the schools to assess the *overall health* of the School Board.

The Statement of Net Assets and Statement of Activities report the following activity for the School Board:

Governmental activities – All of the School Board's services are reported here, including instruction, plant services, transportation, and food services. Property taxes, sales taxes, Minimum Foundation Program funds, and state and federal grants finance most of these activities.

REPORTING THE SCHOOL BOARD'S MOST SIGNIFICANT FUNDS

Fund Financial Statements The School Board's fund financial statements provide detailed information about the most significant funds – not the School Board as a whole. Some funds are required to be established by State law and by bond covenants. However, the School Board establishes many other funds to help it control and manage money for particular purposes (like the School Food Service) or to show that it is meeting legal responsibilities for using certain taxes, grants, and other money (like grants the School Board receives from the U.S. Department of Education). The School Board's governmental funds use the following accounting approach:

Governmental funds – All of the School Board's services are reported in governmental funds. Governmental fund reporting focuses on showing how money flows into and out of funds and the balances left at year-end that are available for spending. They are reported using an accounting method called *modified accrual* accounting, which measures cash and all other *financial* assets that can readily be converted to cash. The governmental fund statements provide a detailed *short-term view* of the School Board's operations and the services it provides. Governmental fund information helps you determine whether there are more or fewer financial resources that can be spent in the near future to finance the School Board's programs. We describe the relationship (or differences) between governmental *activities* (reported in the Statement of Net Assets and the Statement of Activities) and governmental *funds* in a reconciliation on Statements D and F.

Webster Parish School Board

Management's Discussion and Analysis (MD&A)
June 30, 2003

THE SCHOOL BOARD AS TRUSTEE

Reporting the School Board's Fiduciary Responsibilities The School Board is the trustee, or *fiduciary*, for its student activities funds. All of the School Board's fiduciary activities are reported in the Statements of Fiduciary Assets and Liabilities. These activities are excluded from the School Board's other financial statements because the School Board cannot use these assets to finance its operations. The School Board is responsible for ensuring that the assets reported in these funds are used for their intended purposes.

THE SCHOOL BOARD AS A WHOLE The School Board's net assets were \$17.6 million at June 30, 2003. Of this amount, \$3.1 million was unrestricted. Restricted net assets are reported separately to show legal constraints from debt covenants and enabling legislation that limit the School Board's ability to use those net assets for day-to-day operations. Our analysis below focuses on the net assets (Table 1) and change in net assets (Table 2) of the School Board's governmental activities.

Table 1
Net Assets
(in millions)
June 30,

	Governmental Activities	
	2003	2002
Current and other assets	\$ 18.1	\$ 20.7
Capital assets	<u>22.9</u>	<u>21.0</u>
Total assets	<u>41.0</u>	<u>41.7</u>
Current and other liabilities	(5.3)	(4.8)
Long-term liabilities	<u>(18.1)</u>	<u>(18.7)</u>
Total liabilities	<u>(23.4)</u>	<u>(23.5)</u>
Net assets		
Invested in capital assets, net of debt	7.5	5.7
Restricted	7.0	9.9
Unrestricted	<u>3.1</u>	<u>2.6</u>
Total net assets	<u>\$ 17.6</u>	<u>\$ 18.2</u>

The \$3.1 million in unrestricted net assets of governmental activities represents the *accumulated* results of all past years' operations. It means that if we had to pay off all of our bills *today* including all of our noncapital liabilities (compensated absences for example), we would have \$3.1 million left.

The results of this year's operations for the School Board as a whole are reported in the Statement of Activities. Table 2, below, takes the information from that Statement, rounds off the numbers, and rearranges them slightly so you can see our total revenues for the year.

Webster Parish School Board

Management's Discussion and Analysis (MD&A)
June 30, 2003

Table 2
Changes in Net Assets
(in millions)
For the Years Ended June 30,

	<u>2003</u>	<u>2002</u>
Net Assets - beginning	\$18.2	\$18.9
Revenues:		
Program revenues		
Charges for services	0.8	0.7
Operating grants and contributions	8.5	8.6
Capital grants and contributions	0.0	0.0
General Revenues		
Ad valorem taxes	4.6	4.7
Sales taxes	8.8	8.8
Minimum Foundation Program	28.2	26.7
Other general revenues	<u>1.1</u>	<u>1.4</u>
Total revenues	<u>52.0</u>	<u>49.9</u>
Functions/Program Expenses:		
Instruction		
Regular programs	20.4	19.3
Special programs	8.7	8.5
Other instructional programs	3.1	2.9
Support services		
Student services	1.6	1.5
Instructional staff support	2.3	2.3
General administration	1.7	0.7
School administration	2.9	2.8
Business services	0.4	0.4
Plant services	3.9	3.8
Student transportation services	2.7	2.8
Central services	0.1	0.1
Food Services	3.9	3.9
Community services programs	0.0	0.0
Interest on long-term debt	0.9	0.9
Unallocated depreciation	<u>0.0</u>	<u>0.7</u>
Total expenses	<u>52.6</u>	<u>50.6</u>
Increase (decrease) in net assets	<u>(0.6)</u>	<u>(0.7)</u>
Net Assets - ending	<u>\$ 17.6</u>	<u>\$ 18.2</u>

Webster Parish School Board

Management's Discussion and Analysis (MD&A)
June 30, 2003

GOVERNMENTAL ACTIVITIES As reported in the Statement of Activities included later in the government-wide financial statements, the cost of all of our *governmental* activities this year was \$52.7 million. However, the amount that our taxpayers ultimately financed for these activities through School Board taxes was only \$43.3 million because some of the cost was paid by those who benefitted from the programs (\$0.8 million) or by other governments and organizations who subsidized certain programs with grants and contributions (\$8.5 million). We paid for the remaining "public benefit" portion of our governmental activities with \$5.8 million in taxes, \$28.2 million in state Minimum Foundation Program funds, and with our other revenues, like interest and general entitlements.

In the table below, we have presented the cost of each of the School Board's six largest functions - regular programs instruction, special programs instruction, other instructional programs, school administration, plant services, and school food services, as well as each program's *net* cost (total cost less revenues generated by the activities). As discussed above, net cost shows the financial burden that was placed on the School Board's taxpayers by each of these functions. Providing this information allows our citizens to consider the cost of each function in comparison to the benefits they believe are provided by that function.

	Year Ended June 30, 2003		Year Ended June 30, 2002	
	(in millions)		(in millions)	
	<u>Total Cost</u>	<u>Net Cost</u>	<u>Total Cost</u>	<u>Net Cost</u>
	<u>of Services</u>	<u>of Services</u>	<u>of Services</u>	<u>of Services</u>
Regular programs instruction	\$20.4	\$18.9	\$19.3	\$17.5
Special programs instruction	8.7	5.4	8.5	5.5
Other instructional programs	3.1	2.7	2.9	2.4
School administration	2.9	2.8	2.8	2.8
Plant services	3.9	3.7	3.8	3.8
Food services	3.9	1.1	3.9	1.2
All others	9.8	8.7	9.4	9.1
Totals	<u>\$52.7</u>	<u>\$43.3</u>	<u>\$50.6</u>	<u>\$42.3</u>

THE SCHOOL BOARD'S FUNDS As we noted earlier, the School Board uses funds to help it control and manage money for particular purposes. Looking at funds helps you consider whether the School Board is being accountable for the resources taxpayers and others provide to it but may also give you more insight into the School Board's overall financial health.

As the School Board completed this year, our governmental funds reported a combined fund balance of \$13 million.

Other significant changes in revenues and expenditures which affected fund balances were:

The general fund is our principal operating fund. The fund balance in the general fund remained stable, with the following events occurring:

MFP funding increased \$1.5 million due to an increase from the formula and a repayment of a one-time adjustment. Sales tax revenue decreased \$0.1 million and interest income decreased \$0.2 million due to a decline in interest rates.

Webster Parish School Board

Management's Discussion and Analysis (MD&A)
June 30, 2003

Expenditures in the general fund increased \$1.3 million due mainly to an increase in salaries and benefits. This increase in expenditures was offset partially by a transfer of \$0.9 million from the 1996 sales tax fund to cover the supplements given during the year.

The debt service funds reflects a decrease in fund balance. One bond issue was refunded.

BUDGETARY HIGHLIGHTS As mentioned earlier, the School Board revises its budget as it attempts to deal with unexpected changes in revenues and expenditures. (A schedule showing the School Board's major funds original and final budget amounts compared with actual amounts paid and received is provided later in this report as Required Supplemental Information.)

There was one significant revision made to the 2002-2003 general fund original budget. MFP funding increase of approximately \$1 million was due to an increase in the funding formula and repayment of a one-time adjustment.

CAPITAL ASSET AND DEBT ADMINISTRATION

Capital Assets At June 30, 2003, the School Board had \$49.8 million invested in a broad range of capital assets as shown below. This amount represents a net increase (including additions, and deductions) of just over \$3.2 million, or seven percent, from last year.

Capital Assets at June 30,

	<u>Governmental Activities</u>	
	<u>2003</u>	<u>2002</u>
Land	\$ 211,237	\$ 211,237
Buildings and improvements	36,267,417	36,267,417
Furniture and equipment	6,167,372	5,675,805
Transportation equipment	4,621,509	4,449,461
Construction in progress	<u>2,574,072</u>	<u>0</u>
Totals	<u>\$49,841,607</u>	<u>\$46,603,920</u>

This year's additions of \$3.4 million included transportation equipment of \$0.3 million, and furniture and equipment of \$0.6 million.

DEBT ADMINISTRATION At June 30, 2003, the School Board had \$15.4 million in general obligation bonds outstanding with maturities from 2004 to 2021 with interest rates ranging from 2.6 to 10 percent. Under state statute, the School Board is legally restricted from incurring long-term bonded debt in excess of 35% of the assessed value of taxable property. At June 30, 2003, the School Board's net bonded debt of \$14.7 million (total bonded debt of \$15.4 million, less assets in debt service funds of \$0.7 million) was well below the legal limit of \$82 million.

	<u>Amount</u>	<u>Ratio of Net Debt to Assessed Value</u>	<u>Debt per Capita</u>
Net direct general obligation bonded debt	<u>\$14,706,446</u>	<u>12.19%</u>	<u>352</u>

The School Board maintained a Baa bond rating from Moody's Investors Service. We present more information about our debt in the notes to the financial statements.

Webster Parish School Board

Management's Discussion and Analysis (MD&A)
June 30, 2003

ECONOMIC FACTORS AND NEXT YEAR'S BUDGETS AND RATES Our elected and appointed officials and citizens consider many factors when setting the School Board's 2003-2004 fiscal year budget and tax rates. One of the most important factors affecting the budget is our student count. The 2003-2004 budget was adopted in September 2003, based on an estimate of students that will be enrolled on October 1. The October 1 student count affects our Minimum Foundation Program (MFP) funding from the state. Approximately 54% of total revenues is from the MFP.

We have projected for the 2003-2004 fiscal year with no major uncertainties anticipated for the future.

CONTACTING THE SCHOOL BOARD'S FINANCIAL MANAGEMENT Our financial report is designed to provide our citizens, taxpayers, parents, students, and investors and creditors with a general overview of the School Board's finances and to show the School Board's accountability for the money it receives. If you have questions about this report or wish to request additional financial information, contact Fred V. Evans, Director of Business and Finance, at Webster Parish School Board, P. O. Box 520, Minden, Louisiana 71058, telephone number (318) 377-7052.

**BASIC FINANCIAL STATEMENTS:
GOVERNMENT-WIDE
FINANCIAL STATEMENTS (GWFS)**

WEBSTER PARISH SCHOOL BOARD

STATEMENT OF NET ASSETS
June 30, 2003

Statement A

	<u>GOVERNMENTAL ACTIVITIES</u>
ASSETS	
Cash and cash equivalents	\$ 2,907,077
Investments	12,277,500
Receivables (net)	2,768,724
Inventory	78,325
Prepaid items	74,990
Capital assets:	
Land	211,237
Capital assets, net of depreciation	<u>22,643,070</u>
TOTAL ASSETS	<u>40,960,923</u>
LIABILITIES	
Accounts, salaries and other payables	5,017,699
Deferred revenue	61,750
Interest payable	246,219
Long-term liabilities	
Due within one year	1,430,143
Due in more than one year	<u>16,630,661</u>
TOTAL LIABILITIES	<u>23,386,472</u>
NET ASSETS	
Invested in capital assets, net of related debt	7,464,307
Restricted for:	
School food service	687,695
Maintenance and operations	517,798
Protested taxes	125,037
Workers' compensation	100,000
Debt service	624,389
Capital projects	1,478,060
Salary, benefits and operation of schools payable from sales taxes	3,429,208
Unrestricted	<u>3,147,957</u>
TOTAL NET ASSETS	<u>\$ 17,574,451</u>

THE NOTES TO THE BASIC FINANCIAL STATEMENTS ARE AN INTEGRAL PART OF THIS STATEMENT.

WEBSTER PARISH SCHOOL BOARD

**STATEMENT OF ACTIVITIES
For the Year Ended June 30, 2003**

Statement B

	PROGRAM REVENUES			NET (EXPENSE) REVENUE AND CHANGES IN NET ASSETS
	EXPENSES	CHARGES FOR SERVICES	OPERATING GRANTS AND CONTRIBUTIONS	
FUNCTIONS/PROGRAMS				
<i>Governmental activities:</i>				
Instruction:				
Regular programs	\$ 20,424,663		\$ 1,479,225	\$ (18,945,438)
Special education programs	8,749,045		3,310,841	(5,438,204)
Other instructional programs	3,088,210		387,053	(2,701,157)
Support services:				
Student services	1,610,840		185,288	(1,425,552)
Instructional staff support	2,269,209		484,831	(1,784,378)
General administration	1,666,009		205,431	(1,460,578)
School administration	2,898,602		146,059	(2,752,543)
Business services	384,067		2,126	(381,941)
Plant services	3,915,181		152,481	(3,762,700)
Student transportation services	2,683,426		146,059	(2,537,367)
Central services	120,008			(120,008)
Food services	3,942,151	770,334	2,051,143	(1,120,674)
Community service programs	24,375			(24,375)
Interest on long-term debt	892,961			(892,961)
Total Governmental Activities	52,668,747	770,334	8,550,537	0
General revenues:				
Taxes:				
Property taxes, levied for general purposes				2,890,649
Property taxes, levied for debt services				1,752,261
Sales taxes				8,775,810
State revenue sharing				248,936
Grants and contributions not restricted to specific programs				
Minimum Foundation Program				28,205,556
Interest and investment earnings				337,317
Miscellaneous				486,182
Total general revenues				42,696,711
Changes in net assets				(651,165)
Net assets - beginning				18,225,616
Net assets - ending				\$ 17,574,451

THE NOTES TO THE BASIC FINANCIAL STATEMENTS ARE AN INTEGRAL PART OF THIS STATEMENT.

**BASIC FINANCIAL STATEMENTS:
FUND FINANCIAL STATEMENTS (FFS)**

WEBSTER PARISH SCHOOL BOARD

GOVERNMENTAL FUNDS

Balance Sheet

June 30, 2003

	1996		
	GENERAL	TITLE I	SALES TAX
ASSETS			
Cash and cash equivalents	\$ 931,164	\$ 0	\$ 655,999
Investments	6,850,000	0	2,750,000
Receivables	970,588	479,379	399,713
Interfund receivables	860,769	0	0
Inventory	0	0	0
Prepaid items	74,990	0	0
TOTAL ASSETS	9,687,511	479,379	3,805,712
LIABILITIES AND FUND BALANCES			
Liabilities:			
Accounts, salaries and other payables	3,500,672	184,967	376,504
Interfund payables	0	294,412	0
Deferred revenues	0	0	0
Total Liabilities	3,500,672	479,379	376,504
Fund Balances:			
Reserved for:			
Debt Service	0	0	0
Inventory	0	0	0
Prepaid items	74,990	0	0
Salaries and benefits	315,798	0	425,073
Workers' compensation	100,000	0	0
Retiree insurance	0	0	1,028,660
Utilities and new buses	0	0	1,418,559
Protested Taxes	30,118	0	0
Five-year cycle	0	0	556,916
Unreserved			
Designated for vocational education	225	0	0
Designated for workers' compensation	175,000	0	0
Designated for fire insurance	124,673	0	0
Reported in:			
General Fund	5,366,035	0	0
Special Revenue	0	0	0
Capital Projects	0	0	0
Total Fund Balances	6,186,839	0	3,429,208
TOTAL LIABILITIES AND FUND BALANCES	\$ 9,687,511	\$ 479,379	\$ 3,805,712

THE NOTES TO THE BASIC FINANCIAL STATEMENTS ARE AN INTEGRAL PART OF THIS STATEMENT.

Statement C

	<u>OTHER</u>		<u>TOTAL</u>	
	<u>GOVERNMENTAL</u>			
\$	1,319,914	\$	2,907,077	
	2,677,500		12,277,500	
	919,044		2,768,724	
	0		860,769	
	78,325		78,325	
	0		74,990	
	<u>4,994,783</u>		<u>18,967,385</u>	
	955,556		5,017,699	
	566,357		860,769	
	<u>61,750</u>		<u>61,750</u>	
	<u>1,583,663</u>		<u>5,940,218</u>	
	624,389		624,389	
	30,271		30,271	
	0		74,990	
	0		740,871	
	0		100,000	
	0		1,028,660	
	0		1,418,559	
	94,919		125,037	
			556,916	
	0		225	
	0		175,000	
	0		124,673	
	0		5,366,035	
	1,204,415		1,204,415	
	<u>1,457,126</u>		<u>1,457,126</u>	
	<u>3,411,120</u>		<u>13,027,167</u>	
\$	<u>4,994,783</u>	\$	<u>18,967,385</u>	



WEBSTER PARISH SCHOOL BOARD

**Reconciliation of the Governmental Funds
Balance Sheet to the Statement of Net Assets
June 30, 2003**

Statement D

Total Fund Balances - Governmental Funds \$ 13,027,167

The cost of capital assets (land, buildings, furniture and equipment) purchased or constructed is reported as an expenditure in governmental funds. The Statement of Net Assets includes those capital assets among the assets of the School Board as a whole. The cost of those capital assets allocated over their estimated useful lives (as depreciation expense) to the various programs reported as governmental activities in the Statement of Activities. Because depreciation expense does not affect financial resources, it is not reported in governmental funds.

Costs of capital assets	\$ 49,841,607	
Depreciation expense to date	<u>(26,987,300)</u>	22,854,307

Long-term liabilities applicable to the School Board's governmental activities are not due and payable in the current period and accordingly are not reported as fund liabilities. All liabilities - both current and long term - are reported in the Statement of Net Assets.

Balances at June 30, 2003 are:

Long-term liabilities		
Compensated absences payable	(2,670,804)	
Bonds payable	(15,390,000)	
Interest payable	<u>(246,219)</u>	<u>(18,307,023)</u>

Net Assets - Governmental Activities **\$ 17,574,451**

THE NOTES TO THE BASIC FINANCIAL STATEMENTS ARE AN INTEGRAL PART OF THIS STATEMENT.

WEBSTER PARISH SCHOOL BOARD

GOVERNMENTAL FUNDS
 Statement of Revenues, Expenditures,
 and Changes in Fund Balances
 For the Year Ended June 30, 2003

	GENERAL	TITLE I	1996 SALES TAX
REVENUES			
Local sources:			
Taxes:			
Ad valorem	\$ 1,581,815	\$ 0	\$ 0
Sales and use	4,116,022	0	4,330,975
Interest earnings	188,832	0	48,725
Food services	540	0	0
Other	435,355	0	0
State sources:			
Equalization	27,313,260	0	0
Other	1,563,466	0	0
Federal sources	160,906	2,033,008	0
Total Revenues	35,360,196	2,033,008	4,379,700
EXPENDITURES			
Current:			
Instruction:			
Regular programs	16,506,604	0	1,529,239
Special programs	5,367,173	1,960,738	456,334
Other instructional programs	2,245,873	0	121,225
Support services:			
Student services	1,444,158	0	110,818
Instructional staff support	1,680,960	0	125,012
General administration	419,236	0	91,338
School administration	2,675,475	0	179,673
Business services	352,738	0	27,197
Plant services	2,545,367	0	138,459
Student transportation services	2,299,291	0	163,431
Central services	114,024	0	5,984
Food services	2,794	0	191,383
Community service programs	10,124	0	0
Capital outlay	453,774	72,270	1,700
Debt service:			
Principal retirement	0	0	0
Interest and bank charges	0	0	0
Total Expenditures	36,117,591	2,033,008	3,141,793
EXCESS (Deficiency) OF REVENUES OVER EXPENDITURES	\$ (757,395)	\$ 0	\$ 1,237,907

Statement E

	OTHER GOVERNMENTAL	TOTAL
\$	3,061,095	\$ 4,642,910
	328,813	8,775,810
	93,231	330,788
	769,794	770,334
	79,089	514,444
	892,296	28,205,556
	112,674	1,676,140
	4,929,419	7,123,333
	<u>10,266,411</u>	<u>52,039,315</u>
	740,916	18,776,759
	923,398	8,707,643
	675,495	3,042,593
	54,083	1,609,059
	453,881	2,259,853
	1,155,435	1,666,009
	0	2,855,148
	0	379,935
	1,208,576	3,892,402
	0	2,462,722
	0	120,008
	3,603,118	3,797,295
	0	10,124
	2,921,866	3,449,610
	1,225,000	1,225,000
	844,188	844,188
	<u>13,805,956</u>	<u>55,098,348</u>
\$	<u>(3,539,545)</u>	\$ <u>(3,059,033)</u>

(CONTINUED)

WEBSTER PARISH SCHOOL BOARD

GOVERNMENTAL FUNDS
 Statement of Revenues, Expenditures,
 and Changes in Fund Balances
 For the Year Ended June 30, 2003

	<u>GENERAL</u>	<u>TITLE I</u>	<u>1996 SALES TAX</u>
OTHER FINANCING SOURCES (USES)			
Transfers in	\$ 932,307	\$ 0	\$ 2,917
Transfers out	(175,004)	0	(869,112)
Bond proceeds	0	0	0
Payments to refund bond escrow agent	0	0	0
 Total Other Financing Sources (Uses)	 <u>757,303</u>	 <u>0</u>	 <u>(866,195)</u>
 Net Change in Fund Balances	 (92)	 0	 371,712
 FUND BALANCES - BEGINNING	 <u>6,186,931</u>	 <u>0</u>	 <u>3,057,496</u>
 FUND BALANCES - ENDING	 <u>\$ 6,186,839</u>	 <u>\$ 0</u>	 <u>\$ 3,429,208</u>

THE NOTES TO THE BASIC FINANCIAL STATEMENTS ARE AN INTEGRAL PART OF THIS STATEMENT.

Statement E

OTHER	
<u>GOVERNMENTAL</u>	<u>TOTAL</u>
\$ 592,876	\$ 1,528,100
(483,984)	(1,528,100)
1,665,000	1,665,000
<u>(1,660,000)</u>	<u>(1,660,000)</u>
113,892	5,000
(3,425,653)	(3,054,033)
<u>6,836,773</u>	<u>16,081,200</u>
<u>\$ 3,411,120</u>	<u>\$ 13,027,167</u>

(CONCLUDED)

WEBSTER PARISH SCHOOL BOARD

**Reconciliation of the Governmental Funds
Statement of Revenues, Expenditures, and Changes in Fund Balances
to the Statement of Activities
For the Year Ended June 30, 2003**

Statement F

Total net change in fund balances - governmental funds \$ (3,054,033)

Amounts reported for governmental activities in the Statement of Activities are different because:

Capital outlays are reported in governmental funds as expenditures. However, in the Statement of Activities, the cost of those assets is allocated over their estimated useful lives as depreciation expense. This is the amount by which depreciation exceeds capital outlays in the period:

Depreciation expense	\$(1,619,431)	
Capital outlays	3,449,610	1,830,179

Repayment of bond principal is an expenditure in the governmental funds, but the repayment reduces long-term liabilities in the Statement of Net Assets. 2,885,000

In the Statement of Activities, certain operating expenses-compensated absences (vacations and sick leave) - are measured by the amounts earned during the year. In the governmental funds, however, expenditures for these items are measured by the amount of financial resources used (essentially, the amounts actually paid). This year, vacation and sick time earned (\$761,948) exceeded the amounts used (\$185,143) by \$576,805 (576,805)

In the Statement of Activities, scrapping of capital assets are reported as a gain or loss net of the book value. Whereas in the governmental funds there is no recognition since there is no inflow/outflow of current financial resources.

Cost of assets scrapped	\$(211,923)	
<u>Accumulated depreciation</u>	<u>190,190</u>	
Net loss		(21,733)

Bond proceeds are reported as financing sources in governmental funds and thus contribute to the change in fund balance. In the statement of net assets, however, issuing debt increases long-term liabilities and does not affect the statement of activities. (1,665,000)

Interest on long-term debt in the Statement of Activities differs from the amount reported in the governmental funds because interest is recognized as an expenditure in the funds when it is due, and thus requires the use of current financial resources. In the Statement of Activities, however, interest expense is recognized as the interest accrues, regardless of when it is due. (48,773)

Change in net assets of governmental activities \$ (651,165)

THE NOTES TO THE BASIC FINANCIAL STATEMENTS ARE AN INTEGRAL PART OF THIS STATEMENT.

WEBSTER PARISH SCHOOL BOARD

FIDUCIARY FUND
STATEMENT OF FIDUCIARY ASSETS AND LIABILITIES
June 30, 2003

Statement G

	<u>AGENCY FUND</u>
ASSETS	
Cash and cash equivalents	\$ <u>629,247</u>
Total assets	<u>629,247</u>
LIABILITIES	
Deposits due others	<u>629,247</u>
Total liabilities	<u>\$ 629,247</u>

THE NOTES TO THE BASIC FINANCIAL STATEMENTS ARE AN INTEGRAL PART OF THIS STATEMENT.

Webster Parish School Board
Notes to the Basic Financial Statements

INDEX

	<u>Page</u>
NOTE 1 - SUMMARY OF SIGNIFICANT ACCOUNTING POLICIES	29
A. REPORTING ENTITY	29
B. FUNDS	29
Governmental funds	29
Fiduciary Funds	30
C. MEASUREMENT FOCUS AND BASIS OF ACCOUNTING	30
Governmental Funds	30
Fiduciary funds	31
D. CASH AND CASH EQUIVALENTS	32
E. INVESTMENTS	32
F. SHORT-TERM INTERFUND RECEIVABLES/PAYABLES	32
G. ELIMINATION AND RECLASSIFICATIONS	32
H. INVENTORY AND PREPAID ITEMS	32
I. CAPITAL ASSETS	32
J. DEFERRED REVENUES	33
K. COMPENSATED ABSENCES	33
L. LONG-TERM LIABILITIES	33
M. RESTRICTED NET ASSETS	33
N. FUND BALANCES OF FUND FINANCIAL STATEMENTS	34
O. SALES TAXES	34
P. USE OF ESTIMATES	34
NOTE 2 - STEWARDSHIP, COMPLIANCE, AND ACCOUNTABILITY	34
A. Excess of Expenditures Over Appropriations in Individual Funds	34
B. Deficit Fund Balance	34
NOTE 3 - LEVIED TAXES	34
NOTE 4 - DEPOSITS	36
NOTE 5 - RECEIVABLES	36
NOTE 6 - FIXED ASSETS	37
NOTE 7 - RETIREMENT SYSTEMS	37
NOTE 8 - OTHER POST-EMPLOYMENT BENEFITS	39
NOTE 9 - ACCOUNTS, SALARIES AND OTHER PAYABLES	39
NOTE 10 - COMPENSATED ABSENCES	39
NOTE 11 - AGENCY FUND DEPOSITS DUE OTHERS	39
NOTE 12 - LONG-TERM LIABILITIES	40
NOTE 13 - INTERFUND TRANSACTIONS	41
NOTE 14 - RESERVED AND DESIGNATED FUND BALANCES	42
NOTE 15 - LITIGATION AND CLAIMS	43
NOTE 16 - ON-BEHALF PAYMENTS FOR FRINGE BENEFITS AND SALARIES	44
NOTE 17 - RISK MANAGEMENT	44
NOTE 18 - DEFEASANCE OF DEBT	44
NOTE 19 - ECONOMIC DEPENDENCY	44

Webster Parish School Board
Notes to the Basic Financial Statements

NOTE 1 - SUMMARY OF SIGNIFICANT ACCOUNTING POLICIES The accompanying financial statements of the Webster Parish School Board have been prepared in conformity with accounting principles generally accepted in the United States of America (GAAP) as applied to governmental units. The Governmental Accounting Standards Board (GASB) is the accepted standard-setting body for establishing governmental accounting and financial reporting principles.

A. REPORTING ENTITY The Webster Parish School Board was created by Louisiana Revised Statute LSA-R.S. 17:51 to provide public education for the children within Webster Parish. The School Board is authorized by LSA-R.S. 17:81 to establish policies and regulations for its own government consistent with the laws of the state of Louisiana and the regulations of the Louisiana Board of Elementary and Secondary Education. The School Board is comprised of twelve members who are elected from twelve districts for terms of four years.

The School Board operates twenty-two schools within the parish with a total enrollment of approximately 7,516 pupils. In conjunction with the regular educational programs, some of these schools offer special education and/or adult education programs. In addition, the School Board provides transportation and school food services for the students.

GASB Statement 14 establishes criteria for determining the governmental reporting entity and component units that should be included within the reporting entity. Under provisions of this Statement, the School Board is considered a *primary government*, since it is a special purpose government that has a separately elected governing body, is legally separate, and is fiscally independent of other state or local governments. As used in GASB Statement 14, *fiscally independent* means that the School Board may, without the approval or consent of another governmental entity, determine or modify its own budget, levy its own taxes or set rates or charges, and issue bonded debt. The School Board also has no *component units*, defined by GASB Statement 14 as other legally separate organizations for which the elected School Board members are financially accountable. There are no other primary governments with which the School Board has a significant relationship.

B. FUNDS The accounts of the School Board are organized and operated on the basis of funds. A fund is an independent fiscal and accounting entity with a self-balancing set of accounts. Fund accounting segregates funds according to their intended purpose and is used to aid management in demonstrating compliance with finance-related legal and contractual provisions. The minimum number of funds are maintained consistent with legal and managerial requirements.

The funds of the School Board are classified into two categories: governmental and fiduciary.

Governmental funds Governmental funds are used to account for the School Board's general government activities, including the collection and disbursement of specific or legally restricted monies, the acquisition or construction of general fixed assets, and the servicing of general long-term debt. The School Board reports the following major governmental funds:

General fund – the primary operating fund of the School Board. It accounts for all financial resources of the School Board, except those required to be accounted for in another fund.

Title I – To improve the educational opportunities of educationally deprived children by helping them succeed in the regular school program, attain grade level proficiency and improve achievement in basic and more advanced skills.

Webster Parish School Board
Notes to the Basic Financial Statements

1996 sales tax – accounts for the proceeds of a one-cent sales tax to be used for salaries and benefits, retirees' insurance, school supplies, technology and operation of schools.

Fiduciary Funds Fiduciary funds account for assets held by the government in a trustee capacity or as an agent on behalf of outside parties, including other governments, or on behalf of other funds within the School Board.

Agency funds are custodial in nature (assets equal liabilities) and do not present results of operations or have a measurement focus. These funds are used to account for assets that the government holds for others in an agency capacity. These agency funds are as follows:

School activities fund – accounts for assets held by the School Board as an agent for the individual schools and school organizations.

C. MEASUREMENT FOCUS AND BASIS OF ACCOUNTING

Government-Wide Financial Statements (GWFS) The Statement of Net Assets and the Statement of Activities displays information about the reporting government as a whole. Fiduciary funds are not included in the GWFS. Fiduciary funds are reported only in the Statement of Fiduciary Net Assets at the fund financial statement level.

The Statement of Net Assets and the Statement of Activities was prepared using the economic resources measurement focus and the accrual basis of accounting. Revenues, expenses, gains, losses, assets, and liabilities resulting from exchange and exchange-like transactions are recognized when the exchange takes place. Revenues, expenses, gains, losses, assets, and liabilities resulting from nonexchange transactions are recognized in accordance with the requirements of GASB Statement No. 33 "Accounting and Financial Reporting for Nonexchange Transactions."

Program revenues Program revenues include charges to customers or applicants who purchase, use, or directly benefit from goods, services, or privileges provided by a given function or segment and grants and contributions that are restricted to meeting the operational or capital requirements of a particular function or segment. Taxes and other items not properly included among program revenues are reported instead as general revenues.

Allocation of indirect expenses The School Board reports all direct expenses by function in the Statement of Activities. Direct expenses are those that are clearly identifiable with a function. Depreciation expense is specifically identified by function and is included in the direct expense of each function. Interest on general long-term debt is considered an indirect expense and is reported separately on the Statement of Activities.

Fund Financial Statements (FFS)

Governmental Funds The accounting and financial reporting treatment applied to a fund is determined by its measurement focus. Governmental fund types use the flow of current financial resources measurement focus and the modified accrual basis of accounting. Under the modified accrual basis of accounting revenues are recognized when susceptible to accrual (i.e., when they are "measurable and available.") "Measurable" means the amount of the transaction can be determined and "available" means collectible within the current period or soon enough thereafter to pay liabilities of the current period. The government considers all revenues available if they are collected within 60 days after year-end.

Webster Parish School Board
Notes to the Basic Financial Statements

Expenditures are recorded in the period in which the School Board incurs the liability, except for debt service payments on general long-term debt, including capital leases, which is recognized when due, with an optional additional accrual in limited situations, and certain compensated absences and claims and judgments which are recognized to the extent the obligations are normally expected to be liquidated with expendable available financial resources. In the absence of an explicit GASB requirement to do otherwise, the School Board accrues a governmental fund liability and expenditure in the period in which the School Board incurs the liability. Governmental fund liabilities and expenditures include liabilities that, once incurred, normally are paid in a timely manner and in full from current financial resources – for example, salaries, professional services, supplies, utilities, and travel. To the extent not paid, such liabilities generally represent claims against current financial resources and are recorded as governmental fund liabilities.

With this measurement focus, only current assets and current liabilities are generally included on the balance sheet. Operating statements of these funds present increases and decreases in net current assets. The governmental funds use the following practices in recording revenues and expenditures:

Revenues

Ad valorem taxes are recognized when all applicable eligibility requirements are met and the resources are available.

Sales taxes are recognized when underlying exchange transaction occurs and the resources are available.

Entitlements and shared revenues (which include state equalization and state revenue sharing) are recorded as unrestricted grants-in-aid at the time of receipt or earlier if the susceptible to accrual criteria are met. Expenditure-driven grants are recognized as revenue when the qualifying expenditures have been incurred and all other grant requirements have been met.

Other receipts become measurable and available when cash is received by the School Board and are recognized as revenue at that time.

Expenditures

Salaries are recorded as paid. Salaries for nine-month employees are accrued at June 30.

Other financing sources (uses) Transfers between funds that are not expected to be repaid (or any other types, such as capital lease transactions, sale of fixed assets, debt extinguishments, long-term debt proceeds, et cetera) are accounted for as other financing sources (uses). These other financing sources (uses) are recognized at the time the underlying events occur.

Fiduciary funds The agency fund is custodial in nature and does not present results of operations or have a measurement focus. Agency funds are accounted for using the accrual basis of accounting.

Webster Parish School Board
Notes to the Basic Financial Statements

D. CASH AND CASH EQUIVALENTS Cash includes amounts in demand deposits, interest-bearing demand deposits and time deposit accounts. Cash equivalents include amounts in time deposits and those investments with original maturities of less than 90 days. Under state law, the School Board may deposit funds in demand deposits, interest-bearing demand deposits, or time deposits with state banks organized under Louisiana law and national banks having their principal offices in Louisiana.

E. INVESTMENTS Under state law, the School Board may invest in United States bonds, treasury notes or certificates. If the original maturities of investments exceed 90 days, they are classified as investments; however, if the original maturities are less than 90 days, they are classified as cash equivalents.

The investments are reflected at fair value except for the following which are permitted per GASB Statement No. 31:

Investments in *nonparticipating* interest-earning contracts, such as nonnegotiable certificates of deposit with redemption terms that do not consider market rates, are reported using a cost-based measure.

Definitions:

Interest-earning investment contracts include time deposits with financial institutions (such as certificates of deposit), repurchase agreements, and guaranteed investment contracts.

F. SHORT-TERM INTERFUND RECEIVABLES/PAYABLES During the course of operations, numerous transactions occur between individual funds for goods provided or services rendered. These receivables and payables are classified as due from other funds or due to other funds on the balance sheet. Short-term interfund loans are classified as interfund receivables/payables.

G. ELIMINATION AND RECLASSIFICATIONS In the process of aggregating data for the statement of net assets and the statement of activities, some amounts reported as interfund activity and balances in the funds were eliminated or reclassified. Interfund receivables and payables were eliminated to minimize the "grossing up" effect on assets and liabilities within the governmental activities column.

H. INVENTORY AND PREPAID ITEMS Inventory is accounted for using the consumption method, where expenditures are recognized as inventory is used.

Inventory of the school food service special revenue fund consists of food purchased by the School Board and commodities granted by the United States Department of Agriculture through the Louisiana Department of Agriculture and Forestry. All inventory items are recorded as expenditures when consumed. Unused commodities at June 30, are reported as deferred revenue. All purchased inventory items are valued at cost (first-in, first-out) and commodities are assigned values based on information provided by the United States Department of Agriculture.

Certain payments to vendors reflect costs applicable to future accounting periods and are recorded as prepaid items.

I. CAPITAL ASSETS Capital assets are recorded at historical cost and depreciated over their estimated useful lives (excluding salvage value). The capitalization threshold is \$1,000. Donated capital assets are recorded at their estimated fair value at the date of donation. Estimated useful life is management's estimate of how long the asset is expected to meet service demands. Vehicles and trailers are assigned a salvage value of five percent of historical costs. Straight line depreciation is used based on the following estimated useful lives:

**Webster Parish School Board
Notes to the Basic Financial Statements**

Buildings	10 - 40 years
Furniture and equipment	3 - 10 years

J. DEFERRED REVENUES The School Board reports deferred revenues on its statement of net assets and fund balance sheet. Deferred revenues arise when resources are received by the School Board before it has a legal claim to them, as when grant monies are received prior to the occurrence of qualifying expenditures. In subsequent periods, when the School Board has a legal claim to the resources, the liability for deferred revenue is removed from the combined balance sheet and the revenue is recognized.

K. COMPENSATED ABSENCES The School Board has the following policy relating to vacation and sick leave:

All 12-month employees earn from 10 to 15 days of vacation leave each year. A maximum of 30 vacation days may be accrued, fifteen of which may be prior to an employee's most recent anniversary date and up to fifteen after the most recent anniversary date.

All School Board employees earn from 10 to 13 days of sick leave each year, depending on their length of employment with the School Board. Upon retirement or death, unused accumulated sick leave of up to 25 days is paid to the employee or to the employee's estate at the employee's current rate of pay. Under the Louisiana Teachers' Retirement System and the Louisiana School Employees' Retirement System, all unpaid sick leave is used in the retirement benefit computation as earned service.

The School Board's recognition and measurement criteria for compensated absences follows:

Vacation leave and other compensated absences with similar characteristics are accrued as a liability as the benefits are earned by the employees when both of the following conditions are met:

- A. The employees' right to receive compensation are attributable to services already rendered.
- B. It is probable that the employer will compensate the employees for the benefits through paid time off or some other means, such as cash payments at termination or retirement.

The School Board should estimate its accrued sick leave liability based on the sick leave accumulated at the balance sheet date by those employees who currently are eligible to receive termination payments as well as other employees who are expected to become eligible in the future to receive such payments. The School Board uses this approach to accrue the liability for sick leave.

L. LONG-TERM LIABILITIES For government-wide reporting, the costs associated with the bonds are recognized over the life of the bond. As permitted by GASB Statement No. 34 the amortization of the costs of bonds will be amortized prospectively from the date of adoption of GASB Statement No. 34.

For fund financial reporting, bond premiums and discounts, as well as issuance costs, are recognized in the period the bonds are issued. Bond proceeds are reported as an other financing source net of the applicable premium or discount. Issuance costs, even if withheld from the actual net proceeds received, are reported as debt service expenditures.

M. RESTRICTED NET ASSETS For the government-wide statement of net assets, net assets are reported as restricted when constraints placed on net asset use are either:

**Webster Parish School Board
Notes to the Basic Financial Statements**

Externally imposed by creditors (such as debt covenants), grantors, contributors, or laws or regulations of other governments;

Imposed by law through constitutional provisions or enabling legislation.

When both restricted and unrestricted resources are available for use, it is the government's policy to use restricted resources first, then unrestricted resources as they are needed.

N. FUND BALANCES OF FUND FINANCIAL STATEMENTS Reservations of fund balance represent amounts that are not appropriable for expenditures or legally segregated for a specific purpose. Designations of fund balance represent tentative management plans that are subject to change.

O. SALES TAXES On July 1, 1969, the voters of Webster Parish approved for an indefinite period, a one percent parish-wide sales tax with the net proceeds of the tax to be used to pay salaries and benefits of all school employees.

The voters approved a one percent parish-wide sales tax for an indefinite period, effective July 1, 1996, with the net proceeds of the tax to be used to pay salaries and benefits for all school employees, retired school employees' hospitalization premiums, instructional programs and materials and purchasing computer software and equipment. Any annual increase in the total revenues of the tax collected after the June 30, 1997, fiscal year shall be used to pay energy costs, maintain air conditioning equipment and systems and purchase school buses.

P. USE OF ESTIMATES The preparation of financial statements in conformity with accounting principles generally accepted in the United States of America requires management to make estimates and assumptions that affect the reported amounts of assets and liabilities and disclosure of contingent assets and liabilities at the date of the financial statement and the reported amounts of revenues and expenditures during the reporting period. Actual results could differ from those estimates.

NOTE 2 - STEWARDSHIP, COMPLIANCE, AND ACCOUNTABILITY

A. Excess of Expenditures Over Appropriations in Individual Funds The following individual funds had actual expenditures over budgeted expenditures for the year ended June 30, 2003:

<u>Fund</u>	<u>Budget</u>	<u>Actual</u>	<u>Amount</u>
Special revenue			
Piney Hills Consortium	59,562	59,622	60

B. Deficit Fund Balance The following funds had a deficit fund balance at June 30, 2003:

<u>Capital Project Fund</u>	<u>Deficit Amount</u>
Dubberly Heflin Sibley Consolidated	<u>\$27,898</u>

These deficits are expected to be eliminated by transfers from the general fund.

NOTE 3 - LEVIED TAXES The School Board levies taxes on real and business personal property located within Webster Parish's boundaries. Property taxes are levied by the School Board on property values assessed by the Webster Parish Tax Assessor and approved by the state of Louisiana Tax Commission.

Webster Parish School Board
Notes to the Basic Financial Statements

The Webster Parish Sheriff's Office bills and collects property taxes for the School Board. Collections are remitted to the School Board monthly.

Property Tax Calendar

Millage rates adopted	October 7, 2002
Levy date	October 7, 2002 (per grand recap)
Tax bills mailed	November 19, 2002
Due date	December 31, 2002
Penalty and interest accrues	January 1, 2003
Lien date	February 7, 2003

Assessed values are established by the Webster Parish Tax Assessor each year on a uniform basis at the following ratios of assessed value to fair market value:

10% land	15% machinery
10% residential improvements	15% commercial improvements
15% industrial improvements	25% public service properties, excluding land

A revaluation of all property is required after 1978 to be completed no less than every four years. The last revaluation was completed for the roll of January 1, 2002. Total assessed value was \$164,021,025 in calendar year 2002. Louisiana state law exempts the first \$7,500 of assessed value of a taxpayer's primary residence from parish property taxes. This homestead exemption was \$43,606,130 of the assessed value in calendar year 2002.

State law requires the sheriff to collect property taxes in the calendar year in which the assessment is made. Property taxes become delinquent January 1 of the following year. If taxes are not paid by the due date, taxes bear interest at the rate of 1.25% per month until the taxes are paid. After notice is given to the delinquent taxpayers, the sheriff is required by the *Constitution of the State of Louisiana* to sell the least quantity of property necessary to settle the taxes and interest owed.

The calendar-year tax roll is prepared by the tax assessor and approved by the State Tax Commission in November of each year. The amount of property taxes to be collected occurs in December, and January and February 2004. All property taxes are recorded in the general, special revenue, debt service and capital projects funds. The School Board considers the date penalty and interest accrues (January 1, 2004) as the date an enforceable legal claim occurs for property taxes. Property tax revenue is recognized in the period for which the taxes are levied (budgeted). Accordingly, the property taxes are budgeted in the 2003-2004 fiscal year of the School Board.

Estimated uncollectible taxes are those taxes based on past experience which will not be collected in the subsequent year and are primarily due to subsequent adjustments to the tax roll. Historically, virtually all ad valorem taxes receivable were collected since they are secured by property. Therefore, there is no allowance for uncollectible taxes.

The following is a summary of authorized and levied (tax rate per \$1,000 assessed value) ad valorem taxes:

Webster Parish School Board
Notes to the Basic Financial Statements

	<u>Authorized Millage</u>	<u>Levied Millage</u>	<u>Expiration Date</u>
Parish-wide taxes:			
Constitutional Tax	5.77	5.77	Statutory
Special Maintenance & Operations	7.48	7.48	2007
Building Maintenance	3.21	3.21	2007
Building Maintenance	3.31	3.31	2007
District taxes - Maintenance Taxes:			
Dubberly Heflin Sibley Consolidated District No. 3	Variable	43.63	2007
District taxes - Sinking Funds:			
Shongaloo Evergreen Consolidated District No. 1	Variable	48.00	2007
Dubberly Heflin Sibley Consolidated District No. 3	Variable	52.50	2008
Doyline District No. 7	Variable	66.10	2011
Cotton Valley District No. 12	Variable	35.50	2001
Sarepta District No. 35	Variable	30.00	2003

NOTE 4 - DEPOSITS At June 30, 2003, the School Board has cash and cash equivalents (book balances) totaling \$3,536,324 as follows:

Deposits are stated at cost, which approximates fair value. Under state law, these deposits (or the resulting bank balances) must be secured by federal deposit insurance or the pledge of securities owned by the fiscal agent bank. The fair value of the pledged securities plus the federal deposit insurance must at all times equal the amount on deposit with the fiscal agent. These securities are held in the name of the pledging fiscal agent bank in a holding or custodial bank that is mutually acceptable to both parties.

At year-end, the School Board's carrying amount of deposits was \$15,813,824 (which includes \$12,277,500 of time deposits) and the bank balance was \$18,226,485. Of the bank balance, \$464,666 was covered by federal depository insurance or by collateral held by the School Board's agent in the School Board's name (GASB Category 1). The remaining balance, \$17,761,819 was collateralized with securities held by the pledging financial institution's trust department or agent but not in the School Board's name (GASB Category 3).

Even though the pledged securities are considered uncollateralized (Category 3) under the provisions of GASB Statement 3, Louisiana Revised Statute 39:1229 imposes a statutory requirement on the custodial bank to advertise and sell the pledged securities within 10 days of being notified by the School Board that the fiscal agent has failed to pay deposited funds upon demand.

NOTE 5 - RECEIVABLES The receivables at June 30, 2003, are as follows:

<u>Class of General Receivable</u>	<u>General</u>	<u>Title I</u>	<u>1996 Sales Tax</u>	<u>Other Governmental</u>	<u>Total</u>
Taxes:					
Ad valorem	\$ 116	\$ 0	\$ 0	\$ 310	\$ 426
Sales and use	399,713	0	399,713	0	799,426
Intergovernmental - grants:					
State	558,616	0	0	112,674	671,290
Federal	0	479,379	0	803,751	1,283,130
Local accounts	<u>12,143</u>	<u>0</u>	<u>0</u>	<u>2,309</u>	<u>14,452</u>
Total	<u>\$970,588</u>	<u>\$479,379</u>	<u>\$399,713</u>	<u>\$919,044</u>	<u>\$2,768,724</u>

No allowance for doubtful accounts has been established as the School Board expects to collect the full balance.

Webster Parish School Board
Notes to the Basic Financial Statements

NOTE 6 - FIXED ASSETS The changes in general fixed assets for the year are as follows:

	<u>Balance Beginning</u>	<u>Additions</u>	<u>Deletions</u>	<u>Balance Ending</u>
Governmental activities				
Land	\$ 211,237	\$ 0	\$ 0	\$ 211,237
Exhaustible capital assets				
Building and improvements	36,267,417	0	0	36,267,417
Furniture and equipment	5,675,805	574,982	83,415	6,167,372
Transportation equipment	4,449,461	300,556	128,508	4,621,509
Construction in progress	<u>0</u>	<u>2,574,072</u>	<u>0</u>	<u>2,574,072</u>
Total	<u>46,603,920</u>	<u>3,449,610</u>	<u>211,923</u>	<u>49,630,370</u>
Less accumulated depreciation				
Building and improvements	19,891,728	715,862	0	20,607,590
Furniture and equipment	3,596,067	657,948	75,629	4,178,386
Transportation equipment	<u>2,070,264</u>	<u>245,621</u>	<u>114,561</u>	<u>2,201,324</u>
Total	<u>25,558,059</u>	<u>1,619,431</u>	<u>190,190</u>	<u>26,987,300</u>
Government activities				
Capital assets, net	<u>\$21,045,861</u>	<u>\$1,830,179</u>	<u>\$ 21,733</u>	<u>\$22,854,307</u>

Depreciation expense was charged to governmental activities as follows:

Regular programs	\$1,071,099
Special education programs	41,402
Other instructional programs	45,617
Student services	1,781
Instructional staff support	9,356
School administration	43,454
Business services	4,132
Plant services	22,779
Student transportation services	220,704
Central services	14,251
Food services	144,856
Total depreciation expense	<u>\$1,619,431</u>

NOTE 7 - RETIREMENT SYSTEMS

Plan description As required by state statute, substantially all School Board employees participate in either the Teachers' Retirement System or the School Employees' Retirement System (the Systems), which are cost-sharing, multiple-employer public employee retirement systems (PERS). Benefit provisions are ultimately approved and amended by the Louisiana Legislature.

**Webster Parish School Board
Notes to the Basic Financial Statements**

Participation in the Teachers' Retirement System is divided into two plans - the Teachers' Regular Plan and the Teachers' Plan A. In general, professional employees (such as teachers and principals) and lunchroom workers are members of the Louisiana Teachers' Retirement System (TRS); other employees, such as custodial personnel and bus drivers, are members of the Louisiana School Employees' Retirement System (LSERS). Generally, all full-time employees are eligible to participate in the system.

With respect to the Teachers' Retirement System Regular Plan, normal retirement is at age 60 with ten years of service, or at any age with 20 years of service. The formula for annual maximum retirement benefits is generally 2% (with less than 25 years of service) or 2.5% (with 25 or more years of service) times the years of creditable service times the average salary of the 36 highest successive months (plus \$300 applicable to persons becoming members prior to July 1, 1986).

Under the Teachers' Retirement System Plan A, normal retirement is generally at any age with 30 or more years of creditable service, at age 55 with at least 25 years of creditable service and at age 60 with at least ten years of creditable service. The retirement benefit formula is generally 3% times the years of creditable service times the average salary of the 36 highest successive months plus \$24 per year of service.

Employees participating in the School Employees' Retirement System are eligible for normal retirement after 30 years of service, or after 25 years of service at age 55 or after ten years of service at age 60. The maximum retirement allowance is computed at 2.5% times the highest 36 months of average salary, times the years of service plus a supplement of \$2.00 per month times the years of service.

Both TRS and LSERS issue annual financial reports. The reports can be obtained by telephoning or writing to the following:

Teachers' Retirement System of Louisiana
Post Office Box 94123
Baton Rouge, Louisiana 70804-9123
(225) 925-6446

Louisiana School Employees' Retirement System
Post Office Box 44516
Baton Rouge, Louisiana 70804
(225) 925-6484

Funding Policy Each system is administered and controlled at the state level by a separate board of trustees, with contribution rates approved and amended by the Louisiana Legislature. Benefits of the systems are funded by employee and employer contributions. Benefits granted by the retirement systems are guaranteed by the state of Louisiana under provisions of the Louisiana Constitution of 1974.

In addition, the employer does not remit to the Teachers' Retirement System, Regular Plan or Plan A, the employer's contribution for the professional improvement program (PIP) portion of payroll. The PIP contribution is made directly to the Retirement System by the state of Louisiana.

Contribution rates (as a percentage of covered salaries) for active plan members as established by the Louisiana Legislature for the year ended June 30, 2003, are as follows:

	<u>Employee</u>	<u>Employer</u>
Louisiana Teachers' Retirement System:		
Regular	8.00%	13.10%
Plan A	9.10%	13.10%
Louisiana School Employees' Retirement System	7.50%	0.00%

**Webster Parish School Board
Notes to the Basic Financial Statements**

Total covered payroll of the School Board for TRS - Regular Plan, TRS - Plan A, and LSERS for the year ended June 30, 2003, amounted to \$25,933,150, \$209,824, and \$2,640,927, respectively. Employer contributions for the year ended June 30, 2003, and each of the three preceding years are as follows:

<u>Fiscal Year Ended</u>TRS.....LSERS.....
	Annual Actuarially Required Contribution	Annual Actuarially Required Contribution
June 30, 2001	\$3,836,541	\$0
June 30, 2002	3,799,749	0
June 30, 2003	3,964,224	0

Annual actuarially required contributions for each plan above is based on the plan's annual financial report for that year except for the year ended June 30, 2003. The annual actuarially required contributions for the year ended June 30, 2003, is based upon each plan's annual financial report for the year ended June 30, 2002, which is the latest information available. The above-required contributions were paid.

NOTE 8 - OTHER POST-EMPLOYMENT BENEFITS In accordance with state statutes, Webster Parish School Board provides certain continuing health care and life insurance benefits for its retired employees. Substantially all of the School Board's employees become eligible for these benefits if they reach normal retirement age while working for the School Board. These benefits for retirees are provided through the State Employees Group Benefits Program. The cost of benefits for retirees are paid jointly by the employee and the School Board. The School Board's cost of retiree benefits for totaled \$2,267,838 for 502 retirees. The School Board's portion of the cost is recognized as an expenditure when the monthly premium is paid.

NOTE 9 - ACCOUNTS, SALARIES AND OTHER PAYABLES The payables at June 30, 2003, are as follows:

	<u>General</u>	<u>Title I</u>	<u>1996 Sales Tax</u>	<u>Other Governmental</u>	<u>Total</u>
Salaries	\$2,777,869	\$183,436	\$370,508	\$376,665	\$3,708,478
Accounts	722,803	1,531	5,996	428,838	1,159,168
Retainage payable	<u>0</u>	<u>0</u>	<u>0</u>	<u>150,053</u>	<u>150,053</u>
Total	<u>\$3,500,672</u>	<u>\$184,967</u>	<u>\$376,504</u>	<u>\$955,556</u>	<u>\$5,017,699</u>

NOTE 10 - COMPENSATED ABSENCES At June 30, 2003, employees of the School Board have accumulated and vested \$2,670,804 of employee leave benefits including \$75,270 of salary-related benefits. These employee leave benefits were computed in accordance with GASB Codification Section C60. This amount is not expected to be paid from current available resources.

NOTE 11 - AGENCY FUND DEPOSITS DUE OTHERS A summary of changes in agency fund deposits due others for the year ended is as follows:

Webster Parish School Board
Notes to the Basic Financial Statements

	<u>Balance Beginning</u>	<u>Additions</u>	<u>Deductions</u>	<u>Balance Ending</u>
Agency fund:				
School activities	<u>\$650,148</u>	<u>\$2,237,076</u>	<u>\$2,257,977</u>	<u>\$629,247</u>

NOTE 12 - LONG-TERM LIABILITIES The following is a summary of the long-term liabilities transactions for the year:

	<u>Bonded Debt</u>	<u>Compensated Absences</u>	<u>Total</u>
Balance beginning of year	\$16,610,000	\$2,093,999	\$18,703,999
Additions	1,665,000	761,948	2,426,948
Deductions	<u>2,885,000</u>	<u>185,143</u>	<u>3,070,143</u>
Balance at end of year	<u>\$15,390,000</u>	<u>\$2,670,804</u>	<u>\$18,060,804</u>
 Amounts due within one year	 <u>\$ 1,245,000</u>	 <u>\$ 185,143</u>	 <u>\$ 1,430,143</u>

Compensated absences are paid from the fund in which the salaries are paid from. Bonded debt payments are paid from the debt service funds.

The individual issues are as follows:

<u>Bond Issue</u>	<u>Original Amount</u>	<u>Interest Rates</u>	<u>Final Payment Due</u>	<u>Interest to Maturity</u>	<u>Principal Outstanding</u>
Shongaloo Evergreen Consolidated (District No. 1) November 5, 2001	\$1,350,000	3.44	2007	\$ 95,116	\$ 1,080,000
Dubberly Heflin Sibley Consolidated (District No. 3) August 1, 1998	7,095,000	4.40 - 9.00	2018	2,631,438	5,995,000
April 10, 2003	1,380,000	2.85	2008	118,289	1,380,000
Doyline (District No. 7) August 1, 1996	4,425,000	4.80 - 10.00	2011	691,385	2,840,000
Sarepta (District No. 35) June 19, 2003	285,000	2.60	2008	20,397	285,000
Cotton Valley (District No. 12) June 1, 2001	4,000,000	4.35 - 7.00	2021	<u>2,105,513</u>	<u>3,810,000</u>
Total				<u>\$5,662,138</u>	<u>\$15,390,000</u>

**Webster Parish School Board
Notes to the Basic Financial Statements**

All principal and interest requirements are funded in accordance with Louisiana law by the annual ad valorem tax levy on taxable property within the parish. At June 30, 2003, the School Board has accumulated \$683,554 in the debt service funds for future debt requirements. The bonds are due as follows:

<u>Year Ending June 30,</u>	<u>Principal Payments</u>	<u>Interest Payments</u>	<u>Total</u>
2004	\$ 1,245,000	\$ 709,249	\$ 1,954,249
2005	1,310,000	659,307	1,969,307
2006	1,375,000	603,891	1,978,891
2007	1,450,000	545,414	1,995,414
2008	1,225,000	486,843	1,711,843
2009-2013	4,120,000	1,737,628	5,857,628
2014-2018	3,755,000	823,348	4,578,348
2019-2021	910,000	96,460	1,006,460
Total	<u>\$15,390,000</u>	<u>\$5,662,140</u>	<u>\$21,052,140</u>

In accordance with Louisiana Revised Statute 39:562, the School Board is legally restricted from incurring long-term bonded debt in excess of 35 percent of the assessed value of taxable property. At June 30, 2003, the statutory limit is \$82,010,513, and outstanding net bonded debt totals \$14,706,446.

NOTE 13 - INTERFUND TRANSACTIONS

Interfund Receivables/Payables:

<u>Receivable Fund</u>	<u>Payable Fund</u>	<u>Amount</u>
General	Title I	\$294,412
	Other governmental	<u>566,357</u>
		<u>\$860,769</u>

The purpose of interfund receivables/payables were to cover expenditures on cost reimbursement programs until reimbursements are received.

Transfers In/Out:

<u>Transfers In</u>	<u>Transfers Out</u>	<u>Amount</u>
General	96 sales tax	\$ 851,307
	Other governmental	81,000
96 sales tax	General	2,917
Other governmental	General	172,087
	96 sales tax	17,805
	Other governmental	<u>402,984</u>
		<u>\$1,528,100</u>

The purpose of the transfers were mainly to cover operating expenditures.

Webster Parish School Board
Notes to the Basic Financial Statements

NOTE 14 - RESERVED AND DESIGNATED FUND BALANCES

Reservations:

Debt service This amount represents the portion of fund balance that has been reserved in the debt service fund for future payment of principal and interest on bonded debt.

Inventory This amount represents the portion of fund balance relating to inventory on hand which is therefore unavailable to be expended for other purposes.

Prepaid items Fund balance is reserved for prepaid items which indicates that fund balances in that amount are not available for appropriation and expenditures.

Salaries and benefits This amount represents the portion of fund balance relating to sales tax collections for salary supplements. Because sales tax collections are dedicated for salaries, the difference between the estimated collections used to calculate salary supplements and actual collections, is unavailable to be expended for other purposes.

Workers' compensation This amount represents the portion of fund balance relating to the security interest established with the state of Louisiana Office of Workers' Compensation and is therefore unavailable to be expended for other purposes.

Retiree insurance This amount represents the portion of fund balance reserved for payment of retiree insurance and is therefore unavailable to be expended for other purposes.

Utilities and new buses This amount represents the portion of fund balance set aside for utilities and new buses and is unavailable to be expended for other purposes.

Protested taxes This amount represents the portion of fund balance relating to protested ad valorem taxes.

Five-Year Cycle This amount represents the portion of fund balance set aside for (computer technology the first five-year cycle) and, salaries and benefits the second five-year cycle.

Designations:

Vocational education This amount represents a portion of fund balance that has been designated to fund vocational education.

Workers' compensation This amount represents a portion of fund balance that has been designated to fund workers' compensation deductible.

Fire insurance This amount represents a portion of fund balance that has been designated to fund fire insurance deductible.

Webster Parish School Board
Notes to the Basic Financial Statements

The following is a summary of transactions relating to the reserved and designated fund balances for the year ended June 30, 2003:

	<u>Balance, Beginning</u>	<u>Additions</u>	<u>Deductions</u>	<u>Balance, Ending</u>
Reservations:				
Debt service	\$ 674,453	\$ 0	\$ 50,064	\$ 624,389
Inventory	27,009	30,271	27,009	30,271
Prepaid items	161,024	0	86,034	74,990
Salaries and benefits	769,590	513,512	542,231	740,871
Workers' compensation	100,000	0	0	100,000
Retiree insurance	917,037	111,623	0	1,028,660
Utilities and new buses	1,404,035	14,524	0	1,418,559
Protested taxes	80,084	44,953	0	125,037
Five-year cycle	509,067	556,916	509,067	556,916
Designations:				
Vocational education	225	0	0	225
Workers' compensation	175,000	0	0	175,000
Fire insurance	124,673	0	0	124,673

NOTE 15 - LITIGATION AND CLAIMS

Construction The School Board has begun construction on a new gymnasium, replacing the roof on the main building, and a new air conditioning and heating system at Cotton Valley.

Litigation The School Board is a defendant in several lawsuits. Management and legal counsel for the School Board believe that the potential claims against the School Board not covered by insurance would not materially affect the School Board's combined financial position.

Grant Disallowance The School Board participates in a number of state and federally assisted grant programs. These programs are subject to compliance audits under the single audit approach. Such audits could lead to request for reimbursement by the grantor agency for expenditures disallowed under the terms of the grants. School Board management believes that the amount of disallowances, if any, which may arise from future audits will not be material.

Tax Arbitrage Rebate Under the Tax Reform Act of 1986, interest earned on the debt proceeds in excess of interest expense prior to the disbursement of the proceeds must be rebated to the Internal Revenue Service (IRS). Management believes there is no tax arbitrage liability at year end.

Self-Insurance The School Board is self-insured for general liability.

Leases The School Board entered into a capital lease on April 2000 for the purchase of computers totaling \$962,000. The computers were never delivered. No payments have been made on the lease. No liability has been recorded in the financial statements.

Webster Parish School Board
Notes to the Basic Financial Statements

NOTE 16 - ON-BEHALF PAYMENTS FOR FRINGE BENEFITS AND SALARIES On-behalf payments for fringe benefits and salaries are direct payments made by an entity (the paying agent) to a third-party recipient for the employees of another, legally separate entity (the employer entity). GASB Statement No. 24 requires employer governments to recognize revenue and expenditures or expenses for these on-behalf payments.

The state of Louisiana made pension contributions directly to the Teachers' Retirement System of Louisiana on behalf of the School Board in the amount of \$20,394. This amount was recognized as state revenue and a corresponding expenditure in the applicable fund from which the salary was paid.

NOTE 17 - RISK MANAGEMENT The School Board is exposed to various risks of loss related to torts; theft of, damage to, and destruction of assets; errors and omissions; injuries to employees; and natural disasters. The School Board currently reports all of its risk management activities in the general fund.

The School Board continues to carry commercial insurance for all other risks of loss except general liability. Settled claims resulting from these risks have not exceeded commercial insurance coverage in any of the past three fiscal years.

NOTE 18 - DEFEASANCE OF DEBT The School Board defeased in prior years certain general obligation bonds by placing the proceeds of new bonds in an irrevocable trust to provide for all future debt service payments on the old bonds. Accordingly, the trust account assets and the liability for the defeased bonds are not included in the School Board's financial statements. The School Board refunded the 1993 Series General Obligation District #35 Bonds to take advantage of the lower interest rates. Net present value savings from refunding incurred during the current fiscal year was \$20,397. This advance refunding results in a reduction of \$26,588 in future debt service payments. At June 30, 2003, \$1,350,000 of bonds outstanding are considered defeased.

NOTE 19 - ECONOMIC DEPENDENCY Statement of Financial Accounting Standards (SFAS) No. 14 requires disclosure in financial statements of a situation where one entity provides more than 10% of the audited entities revenue. The Minimum Foundation funding provided by the state to all public school systems in Louisiana is primarily based on October 1 student count. The state provided \$28,205,556 to the School Board, which represents approximately 54% of the School Board's total revenue for the year.

**Webster Parish School Board
Notes to the Basic Financial Statements**

**REQUIRED SUPPLEMENTAL
INFORMATION**

Webster Parish School Board
Budgetary Comparison Schedule

General Fund and Major Special Revenue Funds With Legally Adopted Annual Budgets

GENERAL FUND The general fund is used to account for resources traditionally associated with government which are not required legally or by sound financial management to be accounted for in another fund.

TITLE I To improve the educational opportunities of educationally deprived children by helping them succeed in the regular school program, attain grade level proficiency and improve achievement in basic and more advanced skills. Primarily for provision of compensatory instructional activities to educationally deprived children that reside in low-income areas and have been selected on the basis of a needs assessment. Services supplement, not supplant, those normally provided by state and local educational agencies.

1996 SALES TAX The 1996 sales tax fund accounts for the proceeds of a one cent sales tax to be used for salaries and benefits, retirees insurance, school supplies, technology and operation of schools.

WEBSTER PARISH SCHOOL BOARD

**GENERAL FUND
Budgetary Comparison Schedule
For the Year Ended June 30, 2003**

Exhibit 1-1

	<u>BUDGETED AMOUNTS</u>		<u>ACTUAL AMOUNTS</u>	<u>VARIANCE WITH FINAL BUDGET</u>
	<u>ORIGINAL</u>	<u>FINAL</u>		<u>POSITIVE (NEGATIVE)</u>
BUDGETARY FUND BALANCES, BEGINNING	\$ 5,141,509	\$ 5,214,152	\$ 6,186,931	\$ 972,779
Resources (inflows)				
Local sources:				
Ad valorem taxes	1,627,250	1,585,416	1,581,815	(3,601)
Sales and use taxes	4,227,568	4,227,568	4,116,022	(111,546)
Interest earnings	275,000	190,000	188,832	(1,168)
Food service	250	250	540	290
Other	230,318	351,318	435,355	84,037
State sources:				
Equalization	26,339,586	27,319,260	27,313,260	(6,000)
Other	1,509,342	1,428,100	1,563,466	135,366
Federal sources	203,476	41,950	160,906	118,956
Transfers from other funds	879,855	879,855	932,307	52,452
Amounts available for appropriations	<u>40,434,154</u>	<u>41,237,869</u>	<u>42,479,434</u>	<u>1,241,565</u>
Charges to appropriations (outflows)				
Instruction:				
Regular programs	16,087,584	16,546,079	16,506,604	39,475
Special education programs	5,143,494	5,366,207	5,367,173	(966)
Other instructional programs	2,382,657	2,309,261	2,245,873	63,388
Support services:				
Student services	1,415,450	1,445,934	1,444,158	1,776
Instructional staff support	1,616,255	1,706,577	1,680,960	25,617
General administration	686,392	571,997	419,236	152,761
School administration	2,688,024	2,729,941	2,675,475	54,466
Business services	358,970	353,028	352,738	290
Plant services	2,614,376	2,541,390	2,545,367	(3,977)
Student transportation services	2,544,556	2,594,197	2,299,291	294,906
Central services	117,499	118,931	114,024	4,907
Food services	2,189	2,189	2,794	(605)
Community service programs	9,750	8,850	10,124	(1,274)
Capital outlay	0	0	453,774	(453,774)
Transfers to other funds	36,426	82,717	175,004	(92,287)
Total charges to appropriations	<u>35,703,622</u>	<u>36,377,298</u>	<u>36,292,595</u>	<u>84,703</u>
BUDGETARY FUND BALANCES, ENDING	<u>\$ 4,730,532</u>	<u>\$ 4,860,571</u>	<u>\$ 6,186,839</u>	<u>\$ 1,326,268</u>

WEBSTER PARISH SCHOOL BOARD

TITLE I
 Budgetary Comparison Schedule
 For the Year Ended June 30, 2003

Exhibit 1-2

	BUDGETED AMOUNTS		ACTUAL AMOUNTS	VARIANCE WITH FINAL BUDGET
	ORIGINAL	FINAL		POSITIVE (NEGATIVE)
BUDGETARY FUND BALANCES, BEGINNING	\$ 0	\$ 0	\$ 0	0
Resources (inflows)				
Federal sources	1,860,781	2,296,342	2,033,008	(263,334)
Amounts available for appropriations	1,860,781	2,296,342	2,033,008	(263,334)
Charges to appropriations (outflows)				
Instruction:				
Special education programs	1,860,781	2,296,342	2,033,008	263,334
Total charges to appropriations	1,860,781	2,296,342	2,033,008	263,334
BUDGETARY FUND BALANCES, ENDING	\$ 0	\$ 0	\$ 0	0

WEBSTER PARISH SCHOOL BOARD

**1996 SALES TAX
Budgetary Comparison Schedule
For the Year Ended June 30, 2003**

Exhibit 1-3

	<u>BUDGETED AMOUNTS</u>		<u>ACTUAL AMOUNTS</u>	<u>VARIANCE WITH FINAL BUDGET</u>
	<u>ORIGINAL</u>	<u>FINAL</u>		<u>POSITIVE</u>
				<u>(NEGATIVE)</u>
BUDGETARY FUND BALANCES, BEGINNING	\$ 3,057,496	\$ 3,057,496	\$ 3,057,496	0
Resources (inflows)				
Local sources:				
Sales and use taxes	4,448,326	4,448,326	4,330,975	(117,351)
Interest earnings	94,000	94,000	48,725	(45,275)
Transfers from other funds	3,820	3,820	2,917	(903)
	<u>7,603,642</u>	<u>7,603,642</u>	<u>7,440,113</u>	<u>(163,529)</u>
Amounts available for appropriations				
Charges to appropriations (outflows)				
Instruction:				
Regular programs	1,938,565	1,938,565	1,530,939	407,626
Special education programs	479,876	479,876	456,334	23,542
Other instructional programs	174,597	174,597	121,225	53,372
Support services:				
Student services	129,347	129,347	110,818	18,529
Instructional staff support	128,431	128,431	125,012	3,419
General administration	100,281	100,281	91,338	8,943
School administration	202,224	202,224	179,673	22,551
Business services	30,238	30,238	27,197	3,041
Plant services	161,930	161,930	138,459	23,471
Student transportation services	180,326	180,326	163,431	16,895
Central services	5,984	5,984	5,984	0
Food services	204,482	204,482	191,383	13,099
Transfers to other funds	809,865	809,865	869,112	(59,247)
	<u>4,546,146</u>	<u>4,546,146</u>	<u>4,010,905</u>	<u>535,241</u>
Total charges to appropriations				
BUDGETARY FUND BALANCES, ENDING	\$ <u>3,057,496</u>	\$ <u>3,057,496</u>	\$ <u>3,429,208</u>	\$ <u>371,712</u>

Webster Parish School Board
Notes to Budgetary Comparison Schedules
For the Year Ended June 30,

A. BUDGETS

General Budget Practices The School Board follows these procedures in establishing the budgetary data reflected in the combined financial statements:

State statute requires budgets be adopted for the general fund and all special revenue funds.

Each year prior to September 15, the Superintendent submits to the Board proposed annual budgets for the general fund and special revenue funds. Public hearings are conducted, prior to the Board's approval, to obtain taxpayer comments. The operating budgets include proposed expenditures and the means of financing them.

Appropriations (unexpended budget balances) lapse at year end.

Formal budget integration (within the accounting records) is employed as a management control device. All budgets are controlled at the division, departmental or project level. Budget amounts included in the accompanying financial statements include the original adopted budget and all subsequent amendments. All budget revisions are approved by the Board.

Encumbrances Encumbrance accounting, under which purchase orders are recorded in order to reserve that portion of the applicable appropriation, is not employed. However, outstanding purchase orders are taken into consideration before expenditures are incurred in order to assure that applicable appropriations are not exceeded.

Budget Basis of Accounting All governmental funds' budgets are prepared on the modified accrual basis of accounting, a basis consistent with accounting principles generally accepted in the United States of America (GAAP). The School Board includes capital outlay in the various functions. Budgeted amounts are as originally adopted or as amended by the Board. Legally, the Board must adopt a balanced budget; that is, total budgeted revenues and other financing sources including fund balance must equal or exceed total budgeted expenditures and other financing uses. State statutes require the Board to amend its budgets when revenues plus projected revenues within a fund are expected to be less than budgeted revenues by five percent or more and/or expenditures within a fund are expected to exceed budgeted expenditures by five percent or more. The School Board approves budgets at the function level and management can transfer amounts between line items within a function.

WEBSTER PARISH SCHOOL BOARD

**Notes to Budgetary Comparison Schedules
For the Year Ended June 30, 2003**

Note B - Budget to GAAP Reconciliation - Explanation of differences between budgetary inflows and outflows and GAAP revenues and expenditures

	GENERAL FUND	1996 SALES TAX
<u>Sources/inflows of resources:</u>		
Actual amounts (budgetary basis) "available for appropriation" from the Budgetary Comparison Schedule	\$ 42,479,434	\$ 7,440,113
The fund balance at the beginning of the year is a budgetary resource but is not a current year revenue for financial reporting purposes	(6,186,931)	(3,057,496)
Transfers from other funds are inflows of budgetary resources but are not revenues for financial reporting purposes	(932,307)	(2,917)
Total revenues as reported on the Statement of Revenues, Expenditures, and changes in Fund Balances - Governmental Funds	\$ 35,360,196	\$ 4,379,700
<u>Uses/outflows of resources:</u>		
Actual amounts (budgetary basis) "Total charges to appropriations" from the Budgetary Comparison Schedule	\$ 36,292,595	\$ 4,010,905
Transfer to other funds are outflows of budgetary resources but are not expenditures for financial reporting purposes	(175,004)	(869,112)
Total expenditures as reported on the Statement of Revenues, Expenditures, and Changes in Fund Balances - Governmental Funds	\$ 36,117,591	\$ 3,141,793

**OTHER SUPPLEMENTAL INFORMATION:
COMBINING NON-MAJOR GOVERNMENTAL FUNDS
AND AGENCY FUNDS**

WEBSTER PARISH SCHOOL BOARD
NONMAJOR GOVERNMENTAL FUNDS
Combining Balance Sheet - By Fund Type
June 30, 2003

Exhibit 2

	<u>SPECIAL REVENUE</u>	<u>DEBT SERVICE</u>	<u>CAPITAL PROJECTS</u>	<u>TOTAL</u>
ASSETS				
Cash and cash equivalents	\$ 562,775	\$ 355,438	\$ 401,701	\$ 1,319,914
Investments	732,000	332,000	1,613,500	2,677,500
Receivables	917,581	253	1,210	919,044
Inventory	78,325	0	0	78,325
TOTAL ASSETS	<u>2,290,681</u>	<u>687,691</u>	<u>2,016,411</u>	<u>4,994,783</u>
LIABILITIES AND FUND BALANCES				
Liabilities:				
Accounts, salaries and other payables	440,493	4,137	510,926	955,556
Interfund payables	538,932	0	27,425	566,357
Deferred revenue	61,750	0	0	61,750
Total Liabilities	<u>1,041,175</u>	<u>4,137</u>	<u>538,351</u>	<u>1,583,663</u>
Fund Balances:				
Reserved for debt service	0	624,389	0	624,389
Reserved for inventory	30,271	0	0	30,271
Reserved for protested taxes	14,820	59,165	20,934	94,919
Unreserved, reported in				
Special Revenue	1,204,415	0	0	1,204,415
Capital Projects	0	0	1,457,126	1,457,126
Total Fund Balances	<u>1,249,506</u>	<u>683,554</u>	<u>1,478,060</u>	<u>3,411,120</u>
TOTAL LIABILITIES AND FUND BALANCES	<u>\$ 2,290,681</u>	<u>\$ 687,691</u>	<u>\$ 2,016,411</u>	<u>\$ 4,994,783</u>

WEBSTER PARISH SCHOOL BOARD

NONMAJOR GOVERNMENTAL FUNDS
 Combining Statement of Revenues, Expenditures,
 and Changes in Fund Balances - By Fund Type
 For the Year Ended June 30, 2003

Exhibit 3

	SPECIAL REVENUE	DEBT SERVICE	CAPITAL PROJECTS	TOTAL
REVENUES				
Local sources:				
Taxes:				
Ad valorem	\$ 778,373	\$ 1,752,261	\$ 530,461	\$ 3,061,095
Sales and use	328,813	0	0	328,813
Interest earnings	14,583	7,162	71,486	93,231
Food services	769,794	0	0	769,794
Other	45,364	24,760	8,965	79,089
State sources:				
Equalization	892,296	0	0	892,296
Other	112,674	0	0	112,674
Federal sources	4,929,419	0	0	4,929,419
Total Revenues	7,871,316	1,784,183	610,912	10,266,411
EXPENDITURES				
Current:				
Instruction:				
Regular programs	729,216	0	11,700	740,916
Special education programs	923,398	0	0	923,398
Other instructional programs	675,495	0	0	675,495
Support services:				
Student services	54,083	0	0	54,083
Instructional staff support	453,881	0	0	453,881
General administration	123,746	67,813	963,876	1,155,435
Plant services	1,208,576	0	0	1,208,576
Food services	3,603,118	0	0	3,603,118
Capital outlay	341,978	0	2,579,888	2,921,866
Debt service:				
Principal retirement	0	1,225,000	0	1,225,000
Interest and bank charges	0	844,188	0	844,188
Total Expenditures	8,113,491	2,137,001	3,555,464	13,805,956
EXCESS (Deficiency) OF REVENUES OVER EXPENDITURES	\$ (242,175)	\$ (352,818)	\$ (2,944,552)	\$ (3,539,545)

(CONTINUED)

WEBSTER PARISH SCHOOL BOARD

**NONMAJOR GOVERNMENTAL FUNDS
Combining Statement of Revenues, Expenditures,
and Changes in Fund Balances- By Fund Type
For the Year Ended June 30, 2003**

Exhibit 3

	<u>SPECIAL REVENUE</u>	<u>DEBT SERVICE</u>	<u>CAPITAL PROJECTS</u>	<u>TOTAL</u>
OTHER FINANCING SOURCES (USES)				
Transfers in	\$ 274,892	\$ 317,984	\$ 0	\$ 592,876
Transfers out	(166,000)	0	(317,984)	(483,984)
Bond proceeds	0	1,665,000	0	1,665,000
Payment made to refund bond escrow agent	0	(1,660,000)	0	(1,660,000)
 Total Other Financing Sources (Uses)	 <u>108,892</u>	 <u>322,984</u>	 <u>(317,984)</u>	 <u>113,892</u>
 Net Change in Fund Balances	 (133,283)	 (29,834)	 (3,262,536)	 (3,425,653)
 FUND BALANCES - BEGINNING	 <u>1,382,789</u>	 <u>713,388</u>	 <u>4,740,596</u>	 <u>6,836,773</u>
 FUND BALANCES - ENDING	 <u>\$ 1,249,506</u>	 <u>\$ 683,554</u>	 <u>\$ 1,478,060</u>	 <u>\$ 3,411,120</u>

(CONCLUDED)

Webster Parish School Board
Non-Major Special Revenue Funds

OTHER ESEA FUNDS

INNOVATIVE EDUCATION PROGRAM STRATEGIES To assist state and local educational agencies to improve elementary and secondary education. Funds may be used for: innovative assistance in the acquisition and use of instructional materials; technology related to the implementation of school bus reforms; promising education reform projects: promoting higher order thinking skills of disadvantaged students; and reform activities associated with Goals 2000.

EISENHOWER PROFESSIONAL DEVELOPMENT STATE GRANTS To ensure that teachers, staff and administrators have access to sustained and intensive high-quality professional development. To challenge state content standards in core academic subjects.

SAFE AND DRUG-FREE SCHOOLS-STATE GRANTS To establish state and local programs of alcohol and drug abuse education and prevention coordinated with related community efforts and resources.

SPECIAL EDUCATION

STATE GRANTS To provide grants to states to assist them in providing a free appropriate public education to all children with disabilities.

PRESCHOOL GRANTS To provide grants to states to assist them in providing a free appropriate public education to preschool disabled children aged three through five years.

SPECIAL FEDERAL FUNDS

VOCATIONAL EDUCATION - BASIC GRANTS TO STATES To make the United States more competitive in the world economy by developing more fully the academic and occupational skills of all segments of the population, principally through concentrating resources on improving educational programs leading to academic and occupational skills needed to work in a technologically advanced society.

ADULT EDUCATION - STATE-ADMINISTERED BASIC GRANT PROGRAM To improve educational opportunities for adults and to encourage the establishment of adult education programs that will enable all adults to acquire basic educational skills necessary to function in a literate society, enable adults who so desire to complete secondary school, and enable adults to benefit from job training and retraining programs and obtain productive employment to more fully enjoy the benefits and responsibilities of citizenship. Special emphasis is given to programs of instruction in computational skills and in speaking, reading, or writing English for those adults who are educationally disadvantaged.

JOB TRAINING PARTNERSHIP ACT To provide job training and related assistance to economically disadvantaged individuals and others who face significant employment barriers. The ultimate goal of the Act is to move trainees into permanent, self-sustaining employment.

PAYMENTS TO STATES FOR CHILD CARE ASSISTANCE (STARTING POINTS) To make grants available to assist low-income families with child care services. The purpose of the program is to increase the availability, affordability, and quality of child care and to increase the availability of early childhood development and before- and after-school programs.

Webster Parish School Board
Non-Major Special Revenue Funds

JOB OPPORTUNITIES AND BASIC SKILLS TRAINING (PROJECT INDEPENDENCE) To assure that needy families with children obtain the education, training and employment that will help them avoid long-term welfare dependency.

GOALS 2000 – STATE AND LOCAL EDUCATION SYSTEMIC IMPROVEMENT GRANTS To provide grants to state education agencies (SEAs) on a formula basis to support the development and implementation of comprehensive reform plans at the state, local and school levels to improve the teaching and learning of all children. To support top-down and bottom-up reform by requiring SEAs to flow 90 percent of funds to local education agencies (LEAs) and LEAs to flow funds to schools. To support the establishment by states and localities of high standards in their core content areas. All aspects of the educational process are aligned including, but not limited to assessments, curriculum, professional development, and preservice training.

BUILDING MAINTENANCE TAX To account for the proceeds of an ad valorem tax dedicated for maintenance and upkeep of school facilities.

SCHOOL FOOD SERVICE To assist through cash grants and food donations in providing a nutritious breakfast and lunch service for school students and to encourage the domestic consumption of nutritious agricultural commodities.

PINEY HILLS CONSORTIUM To provide educators and learners increased access to technology resources, and professional development for both personal and classroom use. The goal is to impact student achievement by providing professional educators with the skills and resources needed in the classroom to integrate technology across the curriculum.

TECHNOLOGY LITERACY CHALLENGE This program provides funding for professional development in the use of technologies that enhance teachers' effectiveness and support student learning and achievement.

EDUCATIONAL EXCELLENCE To account for the tobacco settlement money received from the state.

COMPREHENSIVE SCHOOL REFORM To provide financial incentives for schools that need to substantially improve student achievement, particularly Title I schools.

LEASE FUNDS

Springhill
Shongaloo
Minden

The lease funds represent accounts designated for royalty payments from School Board owned land. These funds can be used for any area of educational improvement in the school district.

WEBSTER PARISH SCHOOL BOARD
NONMAJOR SPECIAL REVENUE FUNDS
Combining Balance Sheet
June 30, 2003

	OTHER ESEA FUNDS	SPECIAL EDUCATION	SPECIAL FEDERAL FUNDS
ASSETS			
Cash and cash equivalents	\$ 0	\$ 0	\$ 0
Investments	0	0	0
Receivables	183,907	228,522	80,960
Inventory	0	0	0
 TOTAL ASSETS	 183,907	 228,522	 80,960
 LIABILITIES AND FUND BALANCES			
Liabilities:			
Accounts, salaries and other payables	71,269	23,254	28,575
Interfund payable	112,638	205,268	38,689
Deferred revenue	0	0	13,696
 Total Liabilities	 183,907	 228,522	 80,960
 Fund Balances:			
Reserved for inventory	0	0	0
Reserved for protested taxes	0	0	0
Unreserved and undesignated	0	0	0
 Total Fund Balances	 0	 0	 0
 TOTAL LIABILITIES AND FUND BALANCES	 \$ 183,907	 \$ 228,522	 \$ 80,960

Exhibit 4

BUILDING MAINTENANCE TAX	SCHOOL FOOD SERVICE	PINEY HILLS CONSORTIUM	TECHNOLOGY LITERACY CHALLENGE	EDUCATION EXCELLENCE	COMPREHENSIVE SCHOOL REFORM
\$ 182,910	\$ 363,820	13,759	\$ 0	\$ 0	0
400,000	300,000	0	0	0	0
57	195,296	0	40,429	112,674	75,247
0	78,325	0	0	0	0
<u>582,967</u>	<u>937,441</u>	<u>13,759</u>	<u>40,429</u>	<u>112,674</u>	<u>75,247</u>
65,169	201,692	4,521	4,254	28,828	12,931
0	0	0	36,175	83,846	62,316
0	48,054	0	0	0	0
<u>65,169</u>	<u>249,746</u>	<u>4,521</u>	<u>40,429</u>	<u>112,674</u>	<u>75,247</u>
0	30,271	0	0	0	0
14,820	0	0	0	0	0
<u>502,978</u>	<u>657,424</u>	<u>9,238</u>	<u>0</u>	<u>0</u>	<u>0</u>
<u>517,798</u>	<u>687,695</u>	<u>9,238</u>	<u>0</u>	<u>0</u>	<u>0</u>
<u>\$ 582,967</u>	<u>\$ 937,441</u>	<u>\$ 13,759</u>	<u>\$ 40,429</u>	<u>\$ 112,674</u>	<u>\$ 75,247</u>

(CONTINUED)

WEBSTER PARISH SCHOOL BOARD
NONMAJOR SPECIAL REVENUE FUNDS
Combining Balance Sheet
June 30, 2003

Exhibit 4

	<u>SPRINGHILL LEASE</u>	<u>SHONGALOO LEASE</u>	<u>MINDEN LEASE</u>	<u>TOTAL</u>
ASSETS				
Cash and cash equivalents	\$ 852	\$ 1,362	\$ 72	\$ 562,775
Investments	5,000	22,000	5,000	732,000
Receivables	255	234	0	917,581
Inventory	0	0	0	78,325
TOTAL ASSETS	<u>6,107</u>	<u>23,596</u>	<u>5,072</u>	<u>2,290,681</u>
LIABILITIES AND FUND BALANCES				
Liabilities:				
Accounts, salaries and other payables	0	0	0	440,493
Interfund payable	0	0	0	538,932
Deferred revenue	0	0	0	61,750
Total Liabilities	<u>0</u>	<u>0</u>	<u>0</u>	<u>1,041,175</u>
Fund Balances:				
Reserved for inventory	0	0	0	30,271
Reserved for protested taxes	0	0	0	14,820
Unreserved and undesignated	6,107	23,596	5,072	1,204,415
Total Fund Balances	<u>6,107</u>	<u>23,596</u>	<u>5,072</u>	<u>1,249,506</u>
TOTAL LIABILITIES AND FUND BALANCES	<u>\$ 6,107</u>	<u>\$ 23,596</u>	<u>\$ 5,072</u>	<u>\$ 2,290,681</u>

(CONCLUDED)

Webster Parish School Board

Back-to-School 

WEBSTER PARISH SCHOOL BOARD

NONMAJOR SPECIAL REVENUE FUNDS
 Combining Statement of Revenues, Expenditures,
 and Changes in Fund Balances
 For the Year Ended June 30, 2003

	OTHER ESEA FUNDS	SPECIAL EDUCATION	SPECIAL FEDERAL FUNDS
REVENUES			
Local sources:			
Taxes:			
Ad valorem	\$ 0	\$ 0	\$ 0
Sales and use	0	0	0
Interest earnings	0	0	0
Food services	0	0	0
Other	0	0	0
State sources:			
Equalization	0	0	0
Other	0	0	0
Federal sources	<u>701,506</u>	<u>954,349</u>	<u>656,023</u>
 Total revenues	 <u>701,506</u>	 <u>954,349</u>	 <u>656,023</u>
 EXPENDITURES			
Current:			
Instruction:			
Regular programs	504,484	0	0
Special programs	47,129	876,269	0
Other instructional programs	0	0	482,099
Support services:			
Student services	54,083	0	0
Instructional staff support	55,217	0	36,803
General administration	38,778	55,407	0
Plant services	0	0	0
Food services	0	0	0
Capital outlay	<u>1,815</u>	<u>22,673</u>	<u>137,121</u>
 Total expenditures	 <u>701,506</u>	 <u>954,349</u>	 <u>656,023</u>
 EXCESS (Deficiency) OF REVENUES OVER EXPENDITURES	 <u>\$ 0</u>	 <u>\$ 0</u>	 <u>\$ 0</u>

Exhibit 5

BUILDING MAINTENANCE TAX	SCHOOL FOOD SERVICE	PINEY HILLS CONSORTIUM	TECHNOLOGY LITERACY CHALLENGE	EDUCATION EXCELLENCE	COMPREHENSIVE SCHOOL REFORM
\$ 778,373	\$ 0	\$ 0	\$ 0	\$ 0	\$ 0
40,205	288,608	0	0	0	0
8,085	5,983	0	0	0	0
0	769,794	0	0	0	0
0	2,560	37,277	0	0	0
124,114	768,182	0	0	0	0
0	0	0	0	112,674	0
0	2,049,795	0	312,675	0	255,071
<u>950,777</u>	<u>3,884,922</u>	<u>37,277</u>	<u>312,675</u>	<u>112,674</u>	<u>255,071</u>
0	0	0	0	0	224,732
0	0	0	0	0	0
0	0	0	0	193,396	0
0	0	0	0	0	0
0	0	59,622	271,900	0	30,339
29,561	0	0	0	0	0
1,208,576	0	0	0	0	0
0	3,603,118	0	0	0	0
2,350	137,244	0	40,775	0	0
<u>1,240,487</u>	<u>3,740,362</u>	<u>59,622</u>	<u>312,675</u>	<u>193,396</u>	<u>255,071</u>
\$ (289,710)	\$ 144,560	\$ (22,345)	\$ 0	\$ (80,722)	\$ 0

(CONTINUED)

WEBSTER PARISH SCHOOL BOARD
NONMAJOR SPECIAL REVENUE FUNDS
Combining Statement of Revenues, Expenditures,
and Changes in Fund Balances
For the Year Ended June 30, 2003

	<u>OTHER ESEA FUNDS</u>	<u>SPECIAL EDUCATION</u>	<u>SPECIAL FEDERAL FUNDS</u>
OTHER FINANCING SOURCES (USES)			
Transfers in	\$ 0	\$ 0	\$ 0
Transfers out	<u>0</u>	<u>0</u>	<u>0</u>
Total other financing sources (uses)	<u>0</u>	<u>0</u>	<u>0</u>
Net Change in Fund Balances	0	0	0
FUND BALANCES - BEGINNING	<u>0</u>	<u>0</u>	<u>0</u>
FUND BALANCES - ENDING	<u>\$ 0</u>	<u>\$ 0</u>	<u>\$ 0</u>

Exhibit 5

BUILDING MAINTENANCE TAX	SCHOOL FOOD SERVICE	PINEY HILLS CONSORTIUM	TECHNOLOGY LITERACY CHALLENGE	EDUCATION EXCELLENCE	COMPREHENSIVE SCHOOL REFORM
\$ 87,055	\$ 94,690	\$ 12,425	\$ 0	\$ 80,722	\$ 0
0	(166,000)	0	0	0	0
87,055	(71,310)	12,425	0	80,722	0
(202,655)	73,250	(9,920)	0	0	0
720,453	614,445	19,158	0	0	0
\$ 517,798	\$ 687,695	\$ 9,238	\$ 0	\$ 0	\$ 0

(CONTINUED)

WEBSTER PARISH SCHOOL BOARD
NONMAJOR SPECIAL REVENUE FUNDS
Combining Statement of Revenues, Expenditures,
and Changes in Fund Balances
For the Year Ended June 30, 2003

Exhibit 5

	<u>SPRINGHILL LEASE</u>	<u>SHONGALOO LEASE</u>	<u>MINDEN LEASE</u>	<u>TOTAL</u>
REVENUES				
Local sources:				
Taxes:				
Ad valorem	\$ 0	\$ 0	\$ 0	\$ 778,373
Sales and use	0	0	0	328,813
Interest earnings	48	375	92	14,583
Food services	0	0	0	769,794
Other	3,401	2,126	0	45,364
State sources:				
Equalization	0	0	0	892,296
Other	0	0	0	112,674
Federal sources	0	0	0	4,929,419
Total revenues	<u>3,449</u>	<u>2,501</u>	<u>92</u>	<u>7,871,316</u>
EXPENDITURES				
Current:				
Instruction:				
Regular programs	0	0	0	729,216
Special programs	0	0	0	923,398
Other instructional programs	0	0	0	675,495
Support services:				
Student services	0	0	0	54,083
Instructional staff support	0	0	0	453,881
General administration	0	0	0	123,746
Plant services	0	0	0	1,208,576
Food services	0	0	0	3,603,118
Capital outlay	0	0	0	341,978
Total expenditures	<u>0</u>	<u>0</u>	<u>0</u>	<u>8,113,491</u>
EXCESS (Deficiency) OF REVENUES OVER EXPENDITURES	<u>\$ 3,449</u>	<u>\$ 2,501</u>	<u>\$ 92</u>	<u>\$ (242,175)</u>

(CONTINUED)

WEBSTER PARISH SCHOOL BOARD

NONMAJOR SPECIAL REVENUE FUNDS
 Combining Statement of Revenues, Expenditures,
 and Changes in Fund Balances
 For the Year Ended June 30, 2003

Exhibit 5

	SPRINGHILL LEASE	SHONGALOO LEASE	MINDEN LEASE	TOTAL
OTHER FINANCING SOURCES (USES)				
Transfers in	\$ 0	\$ 0	\$ 0	274,892
Transfers out	0	0	0	(166,000)
Total other financing sources (uses)	0	0	0	108,892
Net Changes in Fund Balances	3,449	2,501	92	(133,283)
FUND BALANCES - BEGINNING	2,658	21,095	4,980	1,382,789
FUND BALANCES - ENDING	\$ 6,107	\$ 23,596	\$ 5,072	\$ 1,249,506

(CONCLUDED)

WEBSTER PARISH SCHOOL BOARD

NONMAJOR SPECIAL REVENUE FUND
 Statement of Revenues, Expenditures, and Changes
 in Fund Balances - Budget (GAAP Basis) and Actual
 For the Year Ended June 30, 2003

Exhibit 6-1

	*****OTHER ESEA FUNDS*****		
	BUDGET	ACTUAL	VARIANCE FAVORABLE (UNFAVORABLE)
REVENUES			
Federal sources	\$ 702,106	\$ 701,506	\$ (600)
Total revenues	702,106	701,506	(600)
EXPENDITURES			
Current:			
Instruction:			
Regular programs	450,001	504,484	(54,483)
Special programs	47,348	47,129	219
Support services:			
Student services	54,490	54,083	407
Instructional staff support	150,267	55,217	95,050
General administration	0	38,778	(38,778)
Capital outlay	0	1,815	(1,815)
Total expenditures	702,106	701,506	600
EXCESS (Deficiency) OF REVENUES OVER EXPENDITURES	0	0	0
FUND BALANCES AT BEGINNING OF YEAR	0	0	0
FUND BALANCES AT END OF YEAR	\$ 0	\$ 0	\$ 0

WEBSTER PARISH SCHOOL BOARD

NONMAJOR SPECIAL REVENUE FUND
 Statement of Revenues, Expenditures, and Changes
 in Fund Balances - Budget (GAAP Basis) and Actual
 For the Year Ended June 30, 2003

Exhibit 6-2

	*****SPECIAL EDUCATION*****		
	BUDGET	ACTUAL	VARIANCE FAVORABLE (UNFAVORABLE)
REVENUES			
Federal sources	\$ 954,349	\$ 954,349	\$ 0
Total revenues	<u>954,349</u>	<u>954,349</u>	<u>0</u>
EXPENDITURES			
Current:			
Instruction:			
Special programs	954,349	876,269	78,080
Support services:			
General administration	0	55,407	(55,407)
Capital outlay	<u>0</u>	<u>22,673</u>	<u>(22,673)</u>
Total expenditures	<u>954,349</u>	<u>954,349</u>	<u>0</u>
EXCESS (Deficiency) OF REVENUES OVER EXPENDITURES	0	0	0
FUND BALANCES AT BEGINNING OF YEAR	<u>0</u>	<u>0</u>	<u>0</u>
FUND BALANCES AT END OF YEAR	<u>\$ 0</u>	<u>\$ 0</u>	<u>\$ 0</u>

WEBSTER PARISH SCHOOL BOARD

NONMAJOR SPECIAL REVENUE FUND
 Schedule of Revenues, Expenditures, and Changes
 in Fund Balances - Budget (GAAP Basis) and Actual
 For the Year Ended June 30, 2003

Exhibit 6-3

*****SPECIAL FEDERAL FUNDS*****

	BUDGET	ACTUAL	VARIANCE FAVORABLE (UNFAVORABLE)
REVENUES			
Federal sources	\$ 656,023	\$ 656,023	\$ 0
Total revenues	656,023	656,023	0
EXPENDITURES			
Current:			
Instruction:			
Regular programs	7,372	0	7,372
Other instructional programs	648,651	482,099	166,552
Instructional staff support	0	36,803	(36,803)
Capital outlay	0	137,121	(137,121)
Total expenditures	656,023	656,023	0
EXCESS (Deficiency) OF REVENUES OVER EXPENDITURES	0	0	0
FUND BALANCES AT BEGINNING OF YEAR	0	0	0
FUND BALANCES AT END OF YEAR	\$ 0	\$ 0	\$ 0

WEBSTER PARISH SCHOOL BOARD

NONMAJOR SPECIAL REVENUE FUND
Statement of Revenues, Expenditures, and Changes
in Fund Balances - Budget (GAAP Basis) and Actual
For the Year Ended June 30, 2003

Exhibit 6-4

	*****BUILDING MAINTENANCE TAX*****		
	BUDGET	ACTUAL	VARIANCE FAVORABLE (UNFAVORABLE)
REVENUES			
Local sources:			
Taxes:			
Ad valorem	\$ 780,144	\$ 778,373	\$ (1,771)
Sales and use	43,233	40,205	(3,028)
Interest earnings	25,000	8,085	(16,915)
State sources:			
Equalization	125,816	124,114	(1,702)
Total revenues	<u>974,193</u>	<u>950,777</u>	<u>(23,416)</u>
EXPENDITURES			
Current:			
Support services:			
General administration	29,561	29,561	0
Plant services	1,514,477	1,208,576	305,901
Capital outlay	0	2,350	(2,350)
Total expenditures	<u>1,544,038</u>	<u>1,240,487</u>	<u>303,551</u>
EXCESS (Deficiency) OF REVENUES OVER EXPENDITURES	<u>(569,845)</u>	<u>(289,710)</u>	<u>280,135</u>
OTHER FINANCING SOURCES (USES)			
Transfers in	85,000	87,055	2,055
Total other financing sources (uses)	<u>85,000</u>	<u>87,055</u>	<u>2,055</u>
Net Changes in Fund Balances	(484,845)	(202,655)	282,190
FUND BALANCES AT BEGINNING OF YEAR	<u>711,231</u>	<u>720,453</u>	<u>9,222</u>
FUND BALANCES AT END OF YEAR	<u>\$ 226,386</u>	<u>\$ 517,798</u>	<u>\$ 291,412</u>

WEBSTER PARISH SCHOOL BOARD
NONMAJOR SPECIAL REVENUE FUND
Statement of Revenues, Expenditures, and Changes
in Fund Balances - Budget (GAAP Basis) and Actual
For the Year Ended June 30, 2003

Exhibit 6-5

	*****SCHOOL FOOD SERVICE*****		
	BUDGET	ACTUAL	VARIANCE FAVORABLE (UNFAVORABLE)
REVENUES			
Local sources:			
Taxes:			
Sales and use	\$ 275,137	\$ 288,608	\$ 13,471
Interest earnings	12,891	5,983	(6,908)
Food services	775,720	769,794	(5,926)
Other	1,992	2,560	568
State sources:			
Equalization	762,182	768,182	6,000
Federal sources	2,050,753	2,049,795	(958)
	3,878,675	3,884,922	6,247
EXPENDITURES			
Current:			
Food services	3,760,913	3,603,118	157,795
Capital outlay	0	137,244	(137,244)
	3,760,913	3,740,362	20,551
EXCESS (Deficiency) OF REVENUES OVER EXPENDITURES			
	117,762	144,560	26,798
OTHER FINANCING SOURCES (USES)			
Transfers in	88,501	94,690	6,189
Transfers out	(166,000)	(166,000)	0
	(77,499)	(71,310)	6,189
Net Changes in Fund Balances			
	40,263	73,250	32,987
FUND BALANCES AT BEGINNING OF YEAR			
	0	614,445	614,445
FUND BALANCES AT END OF YEAR			
	\$ 40,263	\$ 687,695	\$ 647,432

WEBSTER PARISH SCHOOL BOARD

NONMAJOR SPECIAL REVENUE FUND
 Statement of Revenues, Expenditures, and Changes
 in Fund Balances - Budget (GAAP Basis) and Actual
 For the Year Ended June 30, 2003

Exhibit 6-6

	*****PINEY HILLS CONSORTIUM*****		
	BUDGET	ACTUAL	VARIANCE FAVORABLE (UNFAVORABLE)
	<u>BUDGET</u>	<u>ACTUAL</u>	<u>(UNFAVORABLE)</u>
REVENUES			
Local sources:			
Other	\$ 47,137	\$ 37,277	\$ (9,860)
	<u>47,137</u>	<u>37,277</u>	<u>(9,860)</u>
Total revenues			
EXPENDITURES			
Current:			
Support services:			
Instructional staff support	59,562	59,622	(60)
	<u>59,562</u>	<u>59,622</u>	<u>(60)</u>
Total expenditures			
EXCESS (Deficiency) OF REVENUES OVER EXPENDITURES	(12,425)	(22,345)	(9,920)
OTHER FINANCING SOURCES (USES)			
Transfers in	12,425	12,425	0
	<u>12,425</u>	<u>12,425</u>	<u>0</u>
Total Other Financing Sources (Uses)			
Net Change in Fund Balance	12,425	(9,920)	(9,920)
FUND BALANCES AT BEGINNING OF YEAR	<u>19,158</u>	<u>19,158</u>	<u>0</u>
FUND BALANCES AT END OF YEAR	<u>\$ 31,583</u>	<u>\$ 9,238</u>	<u>\$ (22,345)</u>

WEBSTER PARISH SCHOOL BOARD
NONMAJOR SPECIAL REVENUE FUND
Statement of Revenues, Expenditures, and Changes
in Fund Balances - Budget (GAAP Basis) and Actual
For the Year Ended June 30, 2003

Exhibit 6-7

	*****TECHNOLOGY LITERACY CHALLENGE*****		
	BUDGET	ACTUAL	VARIANCE FAVORABLE (UNFAVORABLE)
REVENUES			
Federal sources	\$ 399,363	\$ 312,675	\$ (86,688)
Total revenues	399,363	312,675	(86,688)
EXPENDITURES			
Current:			
Support services:			
Instructional staff support	399,363	271,900	127,463
Capital outlay	0	40,775	(40,775)
Total expenditures	399,363	312,675	86,688
EXCESS (Deficiency) OF REVENUES OVER EXPENDITURES	0	0	0
FUND BALANCES AT BEGINNING OF YEAR	0	0	0
FUND BALANCES AT END OF YEAR	\$ 0	\$ 0	\$ 0

WEBSTER PARISH SCHOOL BOARD
NONMAJOR SPECIAL REVENUE FUND
Schedule of Revenues, Expenditures, and Changes
in Fund Balances - Budget (GAAP Basis) and Actual
For the Year Ended June 30, 2003

Exhibit 6-8

	*****EDUCATION EXCELLENCE*****		
	BUDGET	ACTUAL	VARIANCE FAVORABLE (UNFAVORABLE)
REVENUES			
State sources:			
Other	\$ 149,254	\$ 112,674	\$ (36,580)
Total revenues	149,254	112,674	(36,580)
EXPENDITURES			
Current:			
Instruction:			
Other instructional programs	229,976	193,396	36,580
Total expenditures	229,976	193,396	36,580
EXCESS (Deficiency) OF REVENUES OVER EXPENDITURES	(80,722)	(80,722)	0
OTHER FINANCING SOURCES (USES)			
Transfers in	80,722	80,722	0
Total other financing sources (uses)	80,722	80,722	0
Net changes in fund balances	0	0	0
FUND BALANCES AT BEGINNING OF YEAR	0	0	0
FUND BALANCES AT END OF YEAR	\$ 0	\$ 0	\$ 0

WEBSTER PARISH SCHOOL BOARD
NONMAJOR SPECIAL REVENUE FUND
Statement of Revenues, Expenditures, and Changes
in Fund Balances - Budget (GAAP Basis) and Actual
For the Year Ended June 30, 2003

Exhibit 6-9

	*****COMPREHENSIVE SCHOOL REFORM*****		
	BUDGET	ACTUAL	VARIANCE FAVORABLE (UNFAVORABLE)
REVENUES			
Federal sources	\$ 307,698	\$ 255,071	\$ (52,627)
 Total revenues	<u>307,698</u>	<u>255,071</u>	<u>(52,627)</u>
 EXPENDITURES			
Current:			
Instruction:			
Regular programs	131,943	224,732	(92,789)
Support services:			
Instructional staff support	<u>175,755</u>	<u>30,339</u>	<u>145,416</u>
 Total expenditures	<u>307,698</u>	<u>255,071</u>	<u>52,627</u>
 EXCESS (Deficiency) OF REVENUES OVER EXPENDITURES	0	0	0
 FUND BALANCES AT BEGINNING OF YEAR	<u>0</u>	<u>0</u>	<u>0</u>
 FUND BALANCES AT END OF YEAR	<u>\$ 0</u>	<u>\$ 0</u>	<u>\$ 0</u>

WEBSTER PARISH SCHOOL BOARD
NONMAJOR SPECIAL REVENUE FUND
Statement of Revenues, Expenditures, and Changes
in Fund Balances - Budget (GAAP Basis) and Actual
For the Year Ended June 30, 2003

Exhibit 6-10

*****SPRINGHILL LEASE*****

	<u>BUDGET</u>	<u>ACTUAL</u>	<u>VARIANCE FAVORABLE (UNFAVORABLE)</u>
REVENUES			
Local sources:			
Interest earnings	\$ 35	\$ 48	\$ 13
Other	2,500	3,401	901
Total revenues	<u>2,535</u>	<u>3,449</u>	<u>914</u>
EXPENDITURES			
Current:			
Support services:			
Instructional staff support	1,400	0	1,400
Capital outlay	993	0	993
Total expenditures	<u>2,393</u>	<u>0</u>	<u>2,393</u>
EXCESS (Deficiency) OF REVENUES OVER EXPENDITURES	142	3,449	3,307
FUND BALANCES AT BEGINNING OF YEAR	<u>2,658</u>	<u>2,658</u>	<u>0</u>
FUND BALANCES AT END OF YEAR	<u>\$ 2,800</u>	<u>\$ 6,107</u>	<u>\$ 3,307</u>

WEBSTER PARISH SCHOOL BOARD
NONMAJOR SPECIAL REVENUE FUND
Statement of Revenues, Expenditures, and Changes
in Fund Balances - Budget (GAAP Basis) and Actual
For the Year Ended June 30, 2003

Exhibit 6-11

	*****SHONGALOO LEASE*****		
	BUDGET	ACTUAL	VARIANCE FAVORABLE (UNFAVORABLE)
REVENUES			
Local sources:			
Interest earnings	\$ 589	\$ 375	(214)
Other	1,327	2,126	799
Total revenues	1,916	2,501	585
EXPENDITURES			
Current:			
Instruction:			
Regular programs	2,000	0	2,000
Support services:			
Business services	700	0	700
Capital outlay	2,570	0	2,570
Total expenditures	5,270	0	5,270
EXCESS (Deficiency) OF REVENUES OVER EXPENDITURES	(3,354)	2,501	5,855
FUND BALANCES AT BEGINNING OF YEAR	21,095	21,095	0
FUND BALANCES AT END OF YEAR	\$ 17,741	\$ 23,596	\$ 5,855

WEBSTER PARISH SCHOOL BOARD
NONMAJOR SPECIAL REVENUE FUND
Statement of Revenues, Expenditures, and Changes
in Fund Balances - Budget (GAAP Basis) and Actual
For the Year Ended June 30, 2003

Exhibit 6-12

	*****MINDEN LEASE*****		
	BUDGET	ACTUAL	VARIANCE FAVORABLE (UNFAVORABLE)
REVENUES			
Local sources:			
Interest earnings	\$ 143	\$ 92	\$ (51)
Total revenues	143	92	(51)
EXPENDITURES			
Current:			
Instruction:			
Instructional staff support	4,566	0	4,566
Total expenditures	4,566	0	4,566
EXCESS (Deficiency) OF REVENUES OVER EXPENDITURES	(4,423)	92	4,515
FUND BALANCES AT BEGINNING OF YEAR	4,980	4,980	0
FUND BALANCES AT END OF YEAR	\$ 557	\$ 5,072	\$ 4,515

Webster Parish School Board

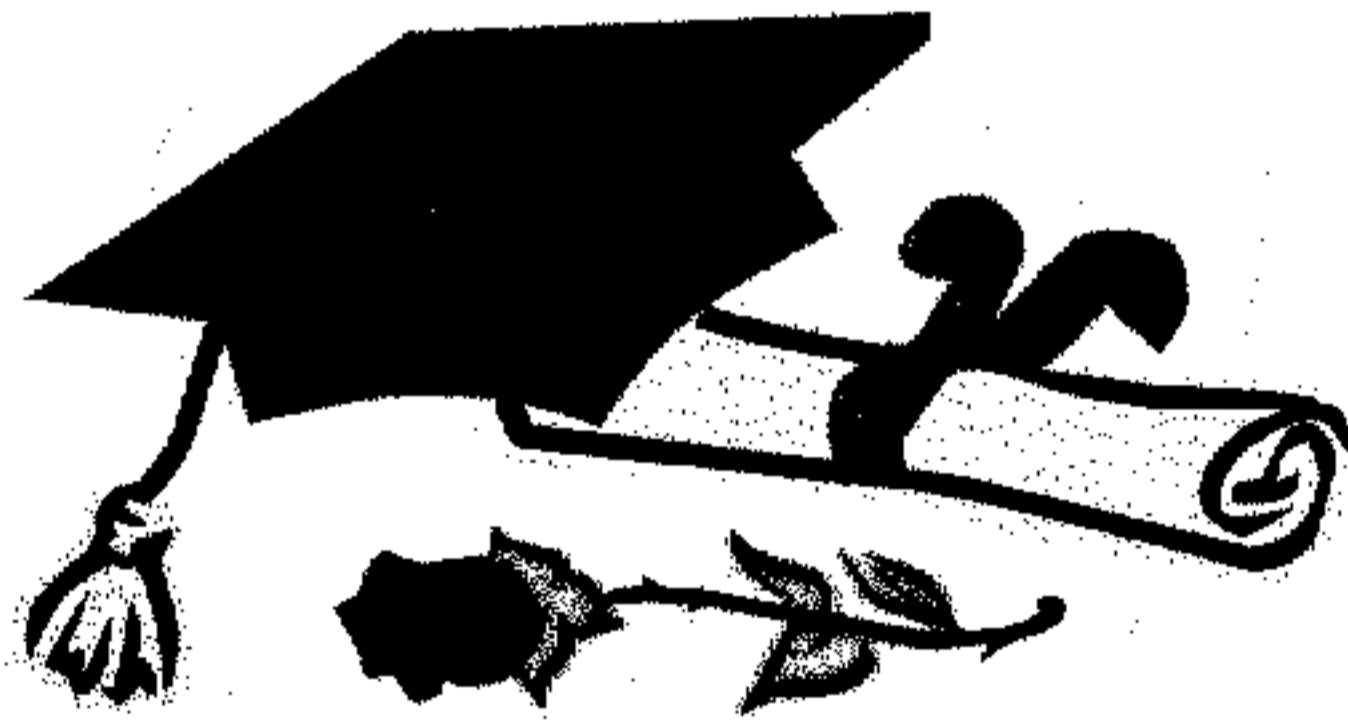

**Webster Parish School Board
Non-Major Debt Service Funds**

The debt service funds are used to accumulate monies to pay outstanding bond issues. The bonds were issued by the respective school districts to acquire lands for building sites and to purchase, erect, and improve school buildings, equipment, and furnishings. The bond issues are financed by an ad valorem tax on property within the territorial boundaries of the respective districts. The School Board has the following debt service funds:

Shongaloo Evergreen Consolidated (District No. 1)

Dubberly Heflin Sibley Consolidated (District No. 3)

Minden (District No. 6)

Doyline (District No. 7)

Cotton Valley (District No. 12)

Sarepta (District No. 35)

Springhill (District No. 8)

WEBSTER PARISH SCHOOL BOARD

NONMAJOR DEBT SERVICE FUNDS

Combining Balance Sheet

June 30, 2003

	SHONGALOO EVERGREEN CONSOLIDATED	DUBBERLY HEFLIN SIBLEY CONSOLIDATED	MINDEN	DOYLINE
ASSETS				
Cash and cash equivalents	\$ 6,336	\$ 184,649	\$ 429	\$ 56,469
Investments	50,000	90,000	13,000	100,000
Receivables	0	0	0	36
TOTAL ASSETS	56,336	274,649	13,429	156,505
LIABILITIES AND FUND BALANCES				
Liabilities:				
Accounts, salaries and other payables	0	0	0	0
Total liabilities	0	0	0	0
FUND BALANCES:				
Reserved for debt service	49,440	249,903	13,429	134,726
Reserved for 2002 protested taxes	6,896	24,746	0	21,779
Total Fund Balances	56,336	274,649	13,429	156,505
TOTAL LIABILITIES AND FUND BALANCES	\$ 56,336	\$ 274,649	\$ 13,429	\$ 156,505

Exhibit 7

COTTON VALLEY	SAREPTA	SPRINGHILL	TOTAL
\$ 97,927	\$ 9,267	\$ 361	\$ 355,438
79,000	0	0	332,000
217	0	0	253
<u>177,144</u>	<u>9,267</u>	<u>361</u>	<u>687,691</u>
0	4,137	0	4,137
0	4,137	0	4,137
173,169	3,361	361	624,389
3,975	1,769	0	59,165
<u>177,144</u>	<u>5,130</u>	<u>361</u>	<u>683,554</u>
<u>\$ 177,144</u>	<u>\$ 9,267</u>	<u>\$ 361</u>	<u>\$ 687,691</u>

WEBSTER PARISH SCHOOL BOARD

NONMAJOR DEBT SERVICE FUNDS
 Combining Statement of Revenues, Expenditures,
 and Changes In Fund Balances
 For the Year Ended June 30, 2003

	SHONGALOO EVERGREEN CONSOLIDATED	DUBBERLY HEFLIN SIBLEY CONSOLIDATED	MINDEN	DOYLINE
REVENUES				
Local sources:				
Taxes:				
Ad valorem	\$ 305,365	\$ 608,290	\$ 3,935	\$ 400,279
Interest earnings	272	2,330	202	2,286
Other	18,231	0	0	0
Total revenues	323,868	610,620	4,137	402,565
EXPENDITURES				
Current:				
Support services:				
General administration	11,478	22,844	0	16,775
Debt service:				
Principal retirement	240,000	490,000	0	275,000
Interest and bank charges	46,979	397,549	0	157,655
Total expenditures	298,457	910,393	0	449,430
EXCESS (Deficiency) OF REVENUES OVER EXPENDITURES	25,411	(299,773)	4,137	(46,865)
OTHER FINANCING SOURCES (USES)				
Transfers in	0	317,984	0	0
Bond proceeds	0	1,380,000	0	0
Payment to escrow agent	0	(1,380,000)	0	0
Total other financing sources (uses)	0	317,984	0	0
Net Changes in Fund Balances	25,411	18,211	4,137	(46,865)
FUND BALANCES - BEGINNING	30,925	256,438	9,292	203,370
FUND BALANCES - ENDING	\$ 56,336	\$ 274,649	\$ 13,429	\$ 156,505

Exhibit 8

COTTON VALLEY	SAREPTA	SPRINGHILL	TOTAL
\$ 332,451	\$ 101,941	\$ 0	\$ 1,752,261
1,813	259	0	7,162
0	6,529	0	24,760
<u>334,264</u>	<u>108,729</u>	<u>0</u>	<u>1,784,183</u>
12,299	4,417	0	67,813
125,000	95,000	0	1,225,000
206,169	35,836	0	844,188
<u>343,468</u>	<u>135,253</u>	<u>0</u>	<u>2,137,001</u>
<u>(9,204)</u>	<u>(26,524)</u>	<u>0</u>	<u>(352,818)</u>
0	0	0	317,984
0	285,000	0	1,665,000
0	(280,000)	0	(1,660,000)
<u>0</u>	<u>5,000</u>	<u>0</u>	<u>322,984</u>
(9,204)	(21,524)	0	(29,834)
<u>186,348</u>	<u>26,654</u>	<u>361</u>	<u>713,388</u>
<u>\$ 177,144</u>	<u>\$ 5,130</u>	<u>\$ 361</u>	<u>\$ 683,554</u>

Webster Parish School Board



**Webster Parish School Board
Non-Major Capital Project Funds**

SCHOOL BUILDING FUNDS

Doyline
Sarepta
Shongaloo
Cotton Valley
Dubberly Heflin Sibley Consolidated

The school building funds account for financial resources to be used to acquire, construct, or improve facilities within the respective districts.

MOORE FIRE INSURANCE The Moore Fire Insurance fund accounts for insurance proceeds from a fire loss at Jerry A. Moore School to be used to acquire, construct, or improve facilities.

LOCAL GOVERNMENT SUPPORT The local government support fund accounts for funds received from the Local Government Assistance Program of the state of Louisiana to be used to acquire, construct, or improve facilities.

CONSOLIDATED #3 LEASE This fund is a consolidation of the Dubberly and Heflin school building funds.

WEBSTER PARISH SCHOOL BOARD
NONMAJOR CAPITAL PROJECT FUNDS
Combining Balance Sheet
June 30, 2003

	<u>DOYLINE</u>	<u>SAREPTA</u>	<u>SHONGALOO</u>	<u>COTTON VALLEY</u>
ASSETS				
Cash and cash equivalents	\$ 9,064	\$ 820	\$ 0	\$ 373,509
Investments	230,000	55,000	58,500	1,000,000
Receivables	0	0	0	0
TOTAL ASSETS	<u>239,064</u>	<u>55,820</u>	<u>58,500</u>	<u>1,373,509</u>
LIABILITIES AND FUND BALANCES				
Liabilities:				
Accounts, salaries and other payables	0	0	0	476,828
Interfund payables	0	2,760	24,665	0
Total Liabilities	<u>0</u>	<u>2,760</u>	<u>24,665</u>	<u>476,828</u>
Fund balances:				
Reserved for protested taxes	0	0	0	0
Undesignated	239,064	53,060	33,835	896,681
Total Fund Balances	<u>239,064</u>	<u>53,060</u>	<u>33,835</u>	<u>896,681</u>
TOTAL LIABILITIES AND FUND BALANCE	<u>\$ 239,064</u>	<u>\$ 55,820</u>	<u>\$ 58,500</u>	<u>\$ 1,373,509</u>

Exhibit 9

<u>DUBBERLY HEFLIN SIBLEY CONSOLIDATED</u>	<u>MOORE FIRE INSURANCE</u>	<u>LOCAL GOVERNMENT SUPPORT</u>	<u>CONSOLIDATED #3 LEASE</u>	<u>TOTAL</u>
\$ 6,200	\$ 6,366	\$ 627	\$ 5,115	401,701
0	170,000	55,000	45,000	1,613,500
0	0	0	1,210	1,210
<u>6,200</u>	<u>176,366</u>	<u>55,627</u>	<u>51,325</u>	<u>2,016,411</u>
34,098	0	0	0	510,926
0	0	0	0	27,425
<u>34,098</u>	<u>0</u>	<u>0</u>	<u>0</u>	<u>538,351</u>
20,934	0	0	0	20,934
(48,832)	176,366	55,627	51,325	1,457,126
<u>(27,898)</u>	<u>176,366</u>	<u>55,627</u>	<u>51,325</u>	<u>1,478,060</u>
\$ 6,200	\$ 176,366	\$ 55,627	\$ 51,325	2,016,411

WEBSTER PARISH SCHOOL BOARD

NONMAJOR CAPITAL PROJECT FUNDS
 Combining Statement of Revenues, Expenditures,
 and Changes in Fund Balances
 For the Year Ended June 30, 2003

	DOYLINE	SAREPTA	SHONGALOO	COTTON VALLEY
REVENUES				
Local sources:				
Taxes:				
Ad valorem	\$ 0	\$ 0	\$ 0	\$ 0
Interest earnings	4,650	1,028	1,188	59,216
Other	0	0	371	1,172
Total revenues	4,650	1,028	1,559	60,388
EXPENDITURES				
Current:				
Instruction:				
Regular programs	0	0	0	0
Support services:				
General administration	0	100	0	942,842
Capital outlay	34,934	6,923	28,813	2,247,198
Total expenditures	34,934	7,023	28,813	3,190,040
EXCESS (Deficiency) OF REVENUES OVER EXPENDITURES	(30,284)	(5,995)	(27,254)	(3,129,652)
OTHER FINANCING SOURCES (USES)				
Transfers out	0	0	0	0
Total other financing sources (uses)	0	0	0	0
Net Changes in Fund Balances	(30,284)	(5,995)	(27,254)	(3,129,652)
FUND BALANCES - BEGINNING	269,348	59,055	61,089	4,026,333
FUND BALANCES - ENDING	\$ 239,064	\$ 53,060	\$ 33,835	\$ 896,681

Exhibit 10

<u>DUBBERLY HEFLIN SIBLEY CONSOLIDATED</u>	<u>MOORE FIRE INSURANCE</u>	<u>LOCAL GOVERNMENT SUPPORT</u>	<u>CONSOLIDATED #3 LEASE</u>	<u>TOTAL</u>
\$ 530,461	\$ 0	\$ 0	\$ 0	530,461
276	3,202	1,018	908	71,486
0	1,000	0	6,422	8,965
<u>530,737</u>	<u>4,202</u>	<u>1,018</u>	<u>7,330</u>	<u>610,912</u>
0	11,700	0	0	11,700
20,934	0	0	0	963,876
<u>257,214</u>	<u>0</u>	<u>0</u>	<u>4,806</u>	<u>2,579,888</u>
<u>278,148</u>	<u>11,700</u>	<u>0</u>	<u>4,806</u>	<u>3,555,464</u>
<u>252,589</u>	<u>(7,498)</u>	<u>1,018</u>	<u>2,524</u>	<u>(2,944,552)</u>
<u>(317,984)</u>	<u>0</u>	<u>0</u>	<u>0</u>	<u>(317,984)</u>
<u>(317,984)</u>	<u>0</u>	<u>0</u>	<u>0</u>	<u>(317,984)</u>
(65,395)	(7,498)	1,018	2,524	(3,262,536)
<u>37,497</u>	<u>183,864</u>	<u>54,609</u>	<u>48,801</u>	<u>4,740,596</u>
<u>\$ (27,898)</u>	<u>\$ 176,366</u>	<u>\$ 55,627</u>	<u>\$ 51,325</u>	<u>\$ 1,478,060</u>

**Webster Parish School Board
Agency Fund**

SCHOOL ACTIVITIES FUND The activities of the various individual school accounts are accounted for in the school activities fund. While the accounts are under the supervision of the School Board, they belong to the individual schools or their student bodies and are not available for use by the School Board.

WEBSTER PARISH SCHOOL BOARD
SCHOOL ACTIVITIES AGENCY FUND
Statement of Changes in Assets and Liabilities
For the Year Ended June 30, 2003

Exhibit 11

	Balance, Beginning	Additions	Deletions	Balance, Ending
ASSETS				
Cash and cash equivalents	\$ <u>650,148</u>	\$ <u>2,237,073</u>	\$ <u>2,257,974</u>	\$ <u>629,247</u>
Total Assets	<u>650,148</u>	<u>2,237,073</u>	<u>2,257,974</u>	<u>629,247</u>
 LIABILITIES				
Deposits due others	<u>650,148</u>	<u>2,237,073</u>	<u>2,257,974</u>	<u>629,247</u>
Total Liabilities	<u>\$ 650,148</u>	<u>\$ 2,237,073</u>	<u>\$ 2,257,974</u>	<u>\$ 629,247</u>

WEBSTER PARISH SCHOOL BOARD
SCHOOL ACTIVITIES AGENCY FUND
Schedule of Changes in Deposits Due Others
For The Year Ended June 30, 2003

Exhibit 12

<u>School</u>	<u>Balance, Beginning</u>	<u>Additions</u>	<u>Deductions</u>	<u>Balance, Ending</u>
Brown Middle School	\$ 10,490	\$ 69,840	\$ 70,648	\$ 9,682
Browning Elementary	9,964	54,579	46,972	17,571
Central Elementary	17,390	76,918	81,605	12,703
Cotton Valley High School	37,376	122,686	127,624	32,438
Doyline High School	85,617	149,343	149,242	85,718
Harper Elementary	26,323	53,900	60,983	19,240
Howell Elementary	17,096	23,948	27,221	13,823
Jones Elementary	43,540	59,038	62,869	39,709
Lakeside Jr. High School	6,616	49,714	47,578	8,752
Minden High School	66,763	380,700	377,033	70,430
Alternative School	2,007	9,277	8,963	2,321
Phillips Middle School	13,435	24,357	25,454	12,338
Richardson Elementary	28,175	92,184	100,020	20,339
Sarepta High School	30,496	242,781	240,944	32,333
Shongaloo High School	49,737	164,574	153,191	61,120
Sibley High School	(275)	141,369	135,408	5,686
Springhill High School	76,484	249,626	243,928	82,182
Springhill Jr. High School	42,297	49,377	58,948	32,726
Stewart Elementary School	21,124	39,210	46,300	14,034
Union Elementary School	707	64,622	61,888	3,441
Webster Jr. High School	64,786	119,030	131,155	52,661
Total	\$ 650,148	\$ 2,237,073	\$ 2,257,974	\$ 629,247

OTHER SUPPLEMENTAL INFORMATION:

**CAPITAL ASSETS
USED IN THE OPERATION
OF GOVERNMENTAL FUNDS**

AND

**SCHEDULE OF COMPENSATION
PAID BOARD MEMBERS**

WEBSTER PARISH SCHOOL BOARD
SCHEDULE OF CAPITAL ASSETS USED IN THE
OPERATION OF GOVERNMENTAL FUNDS -
BY SOURCE
June 30, 2003

Exhibit 13

GOVERNMENTAL FUNDS CAPITAL ASSETS:

Land	\$	211,237
Buildings and improvements		36,267,417
Furniture and equipment		6,167,372
Transportation equipment		4,621,509
Construction in progress		<u>2,574,072</u>

TOTAL CAPITAL ASSETS

\$ 49,841,607

INVESTMENT IN GOVERNMENTAL FUNDS CAPITAL ASSETS:

From General Funds	\$	7,492,739
From School Food Service Fund		1,714,117
From Federal Funds		1,292,593
From Capital Projects Funds		38,846,213
From 96 Sales Tax		<u>495,945</u>

TOTAL INVESTMENT IN CAPITAL ASSETS

\$ 49,841,607

WEBSTER PARISH SCHOOL BOARD

SCHEDULE OF CAPITAL ASSETS USED IN THE
OPERATION OF GOVERNMENTAL FUNDS -
BY FUNCTION
June 30, 2003

Exhibit 14

FUNCTION	BUILDINGS AND		FURNITURE AND		TRANSPORTATION EQUIPMENT	CONSTRUCTION IN PROGRESS	TOTAL
	LAND	IMPROVEMENTS	EQUIPMENT	EQUIPMENT			
Instructional:							
Regular programs	\$ 208,657	\$ 31,915,327	\$ 1,359,980	\$ 8,155	\$ 2,265,183	\$ 35,757,302	
Special programs	0	0	2,189,867	18,054	0	2,207,921	
Other instructional programs	0	0	185,951	0	0	185,951	
Total instructional	208,657	31,915,327	3,735,798	26,209	2,265,183	38,151,174	
Supporting services:							
Instructional staff support	0	0	45,710	0	0	45,710	
General and school administration	2,580	1,450,697	347,692	287,300	102,963	2,191,232	
Central services	0	0	4,797	0	0	4,797	
Business services	0	0	1,500	0	0	1,500	
Food service	0	2,901,393	1,965,106	25,299	205,926	5,097,724	
Plant services	0	0	7,391	0	0	7,391	
Student transportation serv	0	0	59,378	4,282,701	0	4,342,079	
Total supporting services	2,580	4,352,090	2,431,574	4,595,300	308,889	11,690,433	
TOTAL CAPITAL ASSETS	\$ 211,237	\$ 36,267,417	\$ 6,167,372	\$ 4,621,509	\$ 2,574,072	\$ 49,841,607	

WEBSTER PARISH SCHOOL BOARD

SCHEDULE OF CHANGES IN CAPITAL ASSETS -
 USED IN THE OPERATION OF GOVERNMENTAL FUNDS - BY FUNCTION
 For the Year Ended June 30, 2003

Exhibit 15

<u>FUNCTION</u>	<u>BALANCE, BEGINNING</u>	<u>ADDITIONS</u>	<u>DELETIONS</u>	<u>BALANCE, ENDING</u>
<u>Instructional:</u>				
Regular programs	\$ 33,442,770	\$ 2,388,892	\$ 74,360	\$ 35,757,302
Special programs	2,183,699	27,370	3,148	2,207,921
Other instructional programs	0	188,356	2,405	185,951
Total Instructional	<u>35,626,469</u>	<u>2,604,618</u>	<u>79,913</u>	<u>38,151,174</u>
<u>Supporting services:</u>				
Instructional staff support	0	45,710	0	45,710
General and school administration	2,049,659	141,573	0	2,191,232
Central services	0	4,797	0	4,797
Business services	0	1,500	0	1,500
Student transportation services	4,144,283	298,757	100,961	4,342,079
Plant services	0	9,485	2,094	7,391
Food services	<u>4,783,509</u>	<u>343,170</u>	<u>28,955</u>	<u>5,097,724</u>
Total Supporting Services	<u>10,977,451</u>	<u>844,992</u>	<u>132,010</u>	<u>11,690,433</u>
TOTAL CAPITAL ASSETS	<u>\$ 46,603,920</u>	<u>\$ 3,449,610</u>	<u>\$ 211,923</u>	<u>\$ 49,841,607</u>

Webster Parish School Board

**Schedule of Compensation Paid Board Members
For the Year Ended June 30, 2003**

Exhibit 16

The schedule of compensation paid School Board members is in compliance with House Concurrent Resolution No. 54 of the 1979 Session of the Louisiana Legislature. Compensation of the School Board members is included in the general administrative expenditures of the general fund. In accordance with Louisiana Revised Statute 17:56, the School Board members have elected the monthly payment method of compensation. Under this method, each member of the School Board receives \$600 per month and the President receives \$700 per month.

<u>Board Member</u>	<u>Amount</u>
Mr. Willie K. Lynd, III, President	\$ 7,300
Ms. Johnnye Kennon, Vice-President	7,200
Mr. David Beaird	7,200
Ms. Carolyn Boyett	7,700
Mr. Ronnie Broughton	7,200
Mr. Mike Burns	7,200
Mr. Rickey Killian	6,600
Ms. Linda Kinsey	900
Ms. Frankie Mitchell	7,200
Mr. Harold Newsom	7,200
Mr. Malachi Ridgel	7,200
Mr. Greg Stinson	900
Ms. Sue Sullivan	7,200
Ms. Midge Woodard	<u>7,200</u>
Total	<u>\$88,200</u>

Webster Parish School Board

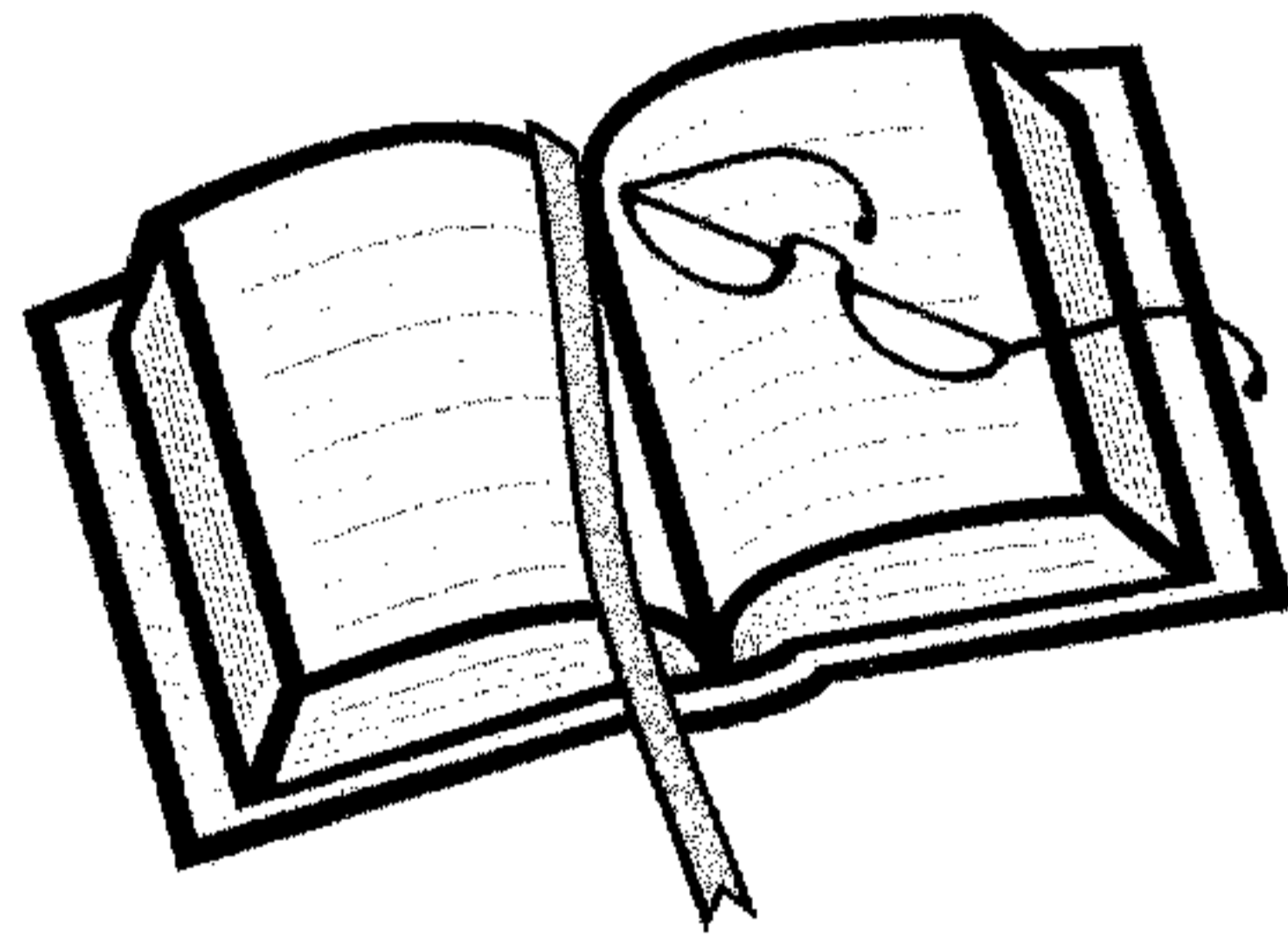

STATISTICAL SECTION

Table 1

WEBSTER PARISH SCHOOL BOARD
Minden, Louisiana

Government-Wide Expenses by Function
Fiscal Year Ended June 30, 2003

	2003	2002
Governmental activities:		
Instruction:		
Regular programs	\$ 20,424,663	19,284,669
Special programs	8,749,045	8,498,269
Other instructional programs	3,088,210	2,910,570
Support services:		
Student services	1,610,840	1,549,078
Instructional staff support	2,269,209	2,269,543
General administration	1,666,009	684,498
School administration	2,898,602	2,812,235
Business services	384,067	373,273
Plant services	3,915,181	3,809,939
Student transportation services	2,683,426	2,789,267
Central services	120,008	40,205
Food services	3,942,151	3,924,678
Community service programs	24,375	20,679
Interest on long-term debt	892,961	929,089
Unallocated depreciation	0	749,156
Total governmental activities	<u>\$ 52,668,747</u>	<u>50,645,148</u>

Note: The above information is available only for the year shown.

Table 2

WEBSTER PARISH SCHOOL BOARD
Minden, Louisiana

Government-Wide Revenues
Fiscal Year Ended June 30, 2003

	2003	2002
Program revenues:		
Charges for services	\$ 770,334	739,390
Operating grants and contributions	8,550,537	7,642,053
Capital grants and contributions	0	0
General revenues:		
Taxes		
Property taxes levied for general purposes	2,890,649	2,875,875
Property taxes levied for debt services	1,752,261	1,795,646
Sales taxes	8,775,810	8,844,208
State revenue sharing	248,936	252,360
Grants and contributions not restricted to specific programs - Minimum Foundation Program	28,205,556	26,739,606
Interest and investment earnings	337,317	551,318
Miscellaneous	486,182	516,819
Total governmental revenues	<u>\$ 52,017,582</u>	<u>49,957,275</u>

Note: The above information is available only for the two years shown.

WEBSTER PARISH SCHOOL BOARD
Minden, Louisiana

General Expenditures by Function - All Governmental Fund Types (1)
Last Ten Fiscal Years Ended June 30, 2003

	1994	1995	1996	1997	1998	1999	2000	2001	2002	2003
Operations:										
Instruction services	\$ 18,526,788	\$ 19,081,086	\$ 19,345,891	\$ 21,869,371	\$ 24,045,781	\$ 25,083,632	\$ 26,635,929	\$ 26,756,268	\$ 26,616,896	\$ 30,526,995
Instruction related services	2,270,488	2,256,929	2,224,741	2,512,342	2,722,270	2,903,371	3,150,582	3,148,102	6,693,778	3,868,912
General administration	530,455	628,226	738,887	802,203	714,729	985,434	656,823	779,289	684,498	1,666,009
School administration	1,769,078	1,796,080	1,720,979	2,003,066	2,129,359	2,464,637	2,482,718	2,574,340	2,812,022	2,855,148
Business services	189,444	188,470	217,308	246,882	297,457	297,503	330,568	329,786	369,018	379,935
Plant services	2,695,936	2,748,447	2,922,925	3,098,088	3,115,810	3,329,331	3,149,161	4,027,250	3,787,534	3,892,402
Student transportation services	1,565,535	1,746,709	1,743,670	1,927,279	2,083,020	2,181,813	2,506,234	2,083,144	2,589,360	2,462,722
Central services		24,568	18,465	3,800	9,005	23,471	32,964	29,495	40,205	120,008
Food services	3,129,828	3,173,377	3,356,461	3,634,316	3,642,132	3,733,605	3,758,811	3,813,256	3,846,046	3,797,295
Community service programs	3,130	3,152	3,336	3,126	13,893	9,072	9,458	8,847	6,428	10,124
Capital outlay	2,162,319	113,787	132,556	401,391	3,265,525	1,713,900	8,044,300	1,363,576	933,384	3,449,610
Debt service:										
Principal retired	955,290	1,012,000	1,059,130	1,096,958	1,154,249	1,279,000	1,357,000	1,136,000	1,120,000	1,225,000
Interest, fiscal charge, and fees	616,201	453,267	392,941	472,710	548,358	680,726	777,590	774,287	900,001	844,188
Total expenditures	\$ 34,414,492	\$ 33,226,098	\$ 33,877,290	\$ 38,071,512	\$ 43,741,588	\$ 44,685,495	\$ 52,892,138	\$ 46,823,640	\$ 50,399,168	\$ 55,098,348

Notes:

(1) The above table includes the following funds, General Fund, Special Revenue Funds, Debt Service Funds, and Capital Project Funds.

WEBSTER PARISH SCHOOL BOARD
Minden, Louisiana

General Revenues by Source - All Governmental Fund Types (1)
Last Ten Fiscal years ended June 30, 2003

	1994	1995	1996	1997	1998	1999	2000	2001	2002	2003
Revenues from local sources:										
Ad valorem taxes	\$ 3,264,129	\$ 3,083,535	\$ 3,124,120	\$ 3,562,141	\$ 3,756,349	\$ 4,746,842	\$ 4,836,606	\$ 4,436,282	\$ 4,671,521	\$ 4,642,910
Sales and use taxes (2)	3,446,622	3,529,692	3,870,864	8,135,147	8,104,647	8,584,065	8,613,702	8,994,530	8,844,208	8,775,810
Interest earnings	196,311	254,954	277,171	426,759	525,084	710,532	691,653	756,697	508,108	330,788
Food services	874,653	662,600	660,553	667,490	665,626	674,153	685,647	685,859	739,390	770,334
Other	44,570	312,844	267,200	324,390	313,617	312,810	230,353	384,442	614,714	514,444
Total revenues from local sources	7,826,285	7,843,625	8,199,906	13,115,927	13,365,323	15,028,402	15,057,961	15,257,810	15,377,941	15,034,286
Revenue from state sources:										
State equalization	20,085,130	19,681,950	19,463,251	20,592,347	22,325,202	23,670,954	24,961,371	25,492,678	26,739,606	28,205,556
Other	812,654	1,662,768	1,074,140	1,114,761	1,677,472	1,672,769	1,280,186	1,368,494	1,447,761	1,676,140
Total revenue from state sources	20,897,784	21,364,718	20,537,391	21,707,108	24,002,674	25,343,723	26,241,557	26,861,172	28,187,367	29,881,696
Revenue from federal sources										
	4,154,534	4,405,506	4,504,778	4,463,816	4,697,327	4,822,322	5,366,414	5,495,116	6,397,356	7,123,333
Total revenue	\$ 32,878,603	\$ 33,613,849	\$ 33,242,077	\$ 39,286,851	\$ 42,065,324	\$ 45,194,447	\$ 46,665,932	\$ 47,614,098	\$ 49,962,664	\$ 52,039,315

Notes:

(1) The above table includes the following funds: General Fund, Special Revenue Funds, Debt Service Funds, and Capital Project Funds.

(2) The school board has collected a 1% sales tax since 1969. Effective July 1, 1996, an additional 1% sales tax is being collected by the school board.

Table 5

WEBSTER PARISH SCHOOL BOARD
Minden, Louisiana

Property Tax Levies and Collections
Last Ten Fiscal Years

Fiscal Year	Total School Board Tax Assessment	Current Tax Collections	Percent of Tax Levy Collected	Delinquent Tax Collections	Total Tax Collections	Total Collections As a Percent of Current Tax Levy	Outstanding Delinquent Taxes	Ratio of Delinquent Taxes to Total Tax Levy
1993-94	3,205,645	3,055,508	95.32%	15,740	3,071,248	95.81%	56,997	1.78%
1994-95	2,984,861	2,847,235	95.39%	24,663	2,871,898	96.22%	43,688	1.46%
1995-96	3,039,544	2,950,640	97.08%	17,816	2,968,456	97.66%	30,213	0.99%
1996-97	3,491,912	3,288,421	94.17%	12,185	3,300,606	94.52%	35,434	1.01%
1997-98	3,689,094	3,531,959	95.74%	14,046	3,546,005	96.12%	26,054	0.71%
1998-99	4,690,332	4,473,561	95.38%	10,247	4,483,808	95.60%	114,819	2.45%
1999-00	4,901,092	N/A	0.00%	N/A	4,863,342	N/A	161,589	3.30%
2000-01	6,356,561	N/A	0.00%	N/A	4,757,774	N/A	116,687	1.84%
2001-02	6,603,300	N/A	0.00%	N/A	N/A	N/A	N/A	0.00%
2002-03	6,602,043	4,645,654	70.37%	N/A	4,645,654	70.37%	N/A	0.00%

Source: Annual audit report for the Webster Parish Sheriff (As Ex-Officio Parish Tax Collector).

N/A : Information was not available at this time.

WEBSTER PARISH SCHOOL BOARD
Minden, Louisiana

Assessed and Estimated Actual Value of Taxable Property
Last Ten Calendar Years

Year	Real Property (1)		Personal Property (1)		Exemptions (2)		Total		Ratio of Total Assessed Value To Total Estimated Actual Value
	Assessed Value	Estimated Actual Value	Assessed Value	Estimated Actual Value	Real Property	Property	Assessed Value	Estimated Actual Value	
1993	78,450,785	636,051,500	44,411,190	296,074,600	34,213,510		88,648,465	932,126,100	9.5%
1994	76,808,970	631,515,823	41,210,740	274,738,267	35,180,450		82,839,260	906,254,090	9.1%
1995	78,367,320	643,694,237	43,163,100	287,754,000	36,076,850		85,453,570	931,448,237	9.2%
1996	82,654,295	676,682,377	49,050,940	327,006,267	36,961,980		94,743,255	1,003,688,644	9.4%
1997	90,619,905	715,672,443	53,252,310	355,015,400	37,897,730		105,974,485	1,070,687,843	9.9%
1998	90,820,345	723,778,690	57,941,725	386,278,167	39,144,680		109,617,390	1,110,056,857	9.9%
1999	93,142,135	742,203,830	62,776,975	418,513,167	40,253,790		115,665,320	1,160,716,997	10.0%
2000	98,497,725	783,752,190	57,737,675	384,917,833	41,609,500		114,625,900	1,168,670,023	9.8%
2001	102,116,000	812,981,477	61,403,055	409,353,700	42,738,220		120,780,835	1,222,335,177	9.9%
2002	101,440,235	822,370,197	62,580,790	417,205,267	43,406,130		120,614,895	1,239,575,464	9.7%

Notes:

(1) Assessed values are established by the Webster Parish Tax Assessor on January 1st of each year at approximately 10-25% of estimated actual value, depending on the property value classification. A revaluation of all property is required to be completed no less than every four years. The last revaluation was completed for the tax roll of 2000.

(2) Homestead exemption is \$75,000 estimated actual value (\$7,500 assessed value) per household.

Source: Grand Recapitulation prepared by Webster Parish Tax Assessor

WEBSTER PARISH SCHOOL BOARD
Minden, Louisiana

Property Tax Rates and Tax Levies - All Direct and Overlapping Governments
Last Ten Calendar Years

Calendar Year	Tax Rates Per \$1,000 of Assessed Value (1)				Tax Levies (1)					
	School		City of Minden		School		City of Minden			
	Parish	District	Parish(2)	District	Parish	District	Parish (2)	District		
1993	19.80	189.50	34.63	119.73	1,755,239	1,450,406	2,645,105	519,325	524,917	6,894,992
1994	19.80	180.10	39.84	119.73	1,640,216	1,344,645	2,891,003	480,884	491,614	6,848,362
1995	19.80	168.95	39.84	119.73	1,691,980	1,347,564	2,982,814	494,845	507,097	7,024,300
1996	19.29	219.50	41.88	117.67	1,827,598	1,664,314	3,530,450	552,375	546,930	8,121,667
1997	19.29	204.30	41.88	107.37	2,044,248	1,644,846	3,960,396	548,807	609,892	8,808,189
1998	19.29	277.80	42.60	128.11	2,114,377	2,575,955	4,177,659	606,221	631,122	10,105,334
1999	19.29	268.70	41.37	135.64	2,231,184	2,669,908	4,260,677	663,066	626,590	10,451,425
2000	19.77	279.63	42.84	154.73	3,088,777	3,267,784	5,901,038	1,065,186	497,401	13,820,186
2001	19.77	275.73	43.07	154.73	3,232,776	3,370,524	6,216,815	1,124,533	514,981	14,459,629
2002	19.77	271.23	44.16	143.48	3,242,760	3,359,283	6,385,481	902,343	502,404	14,392,271

Notes:
 (1) Per Webster Parish Tax Assessor
 (2) The parish taxes include the following:
 District A & B Road Tax
 Courthouse Tax
 Library Tax
 Assessor's Tax
 L. E. Tax

WEBSTER PARISH SCHOOL BOARD
Minden, Louisiana

Ratio of Net General Obligation Bonded Debt
to Assessed Value and Net General Obligation Bonded Debt Per Capita

Last Ten Fiscal Years

Fiscal Year	Webster Population (1)	Assessed Value (2)	Gross Bonded Debt (3)	Less Debt Service Funds (3)	Net Bonded Debt (3)	Ratio of Net Bonded Debt to Assessed Value	Net Bonded Debt Per Capita
1993-94	41,400	88,648,465	8,147,000	796,171	7,350,829	8.29%	178
1994-95	41,700	82,839,260	7,135,000	661,698	6,473,302	7.81%	155
1995-96	42,200	85,453,570	6,117,000	569,110	5,547,890	6.49%	131
1996-97	42,366	94,743,255	9,477,000	612,257	8,864,743	9.36%	209
1997-98	42,366	105,974,485	8,357,000	547,637	7,809,363	7.37%	184
1998-99	43,631	109,617,390	14,173,000	662,031	13,510,969	12.33%	310
1999-00	43,631	115,665,320	14,816,000	556,788	14,259,212	12.33%	327
2000-01	41,831	114,625,900	13,680,000	593,422	13,086,578	11.42%	313
2001-02	41,989	120,780,835	16,610,000	713,388	15,896,612	13.16%	379
2002-03	41,831	120,614,895	15,390,000	683,554	14,706,446	12.19%	352

Notes:

- (1) Louisiana Electronic Assistance Program (LEAP) operated by University of Louisiana at Monroe Center for Business and Economic Research (<http://leap.ulm.edu>). The most recent two years shown are management's estimates.
- (2) From Table 4.
- (3) Includes general obligation bonds payable only.

WEBSTER PARISH SCHOOL BOARD
Minden, Louisiana

Statement of Direct, Overlapping, and Underlying General Obligation Bonded Debt
June 30, 2003

Name of Governmental Unit (1)	Debt Outstanding (2)	Percentage Applicable to This Unit	School Board's Share of Debt
DIRECT:			
Webster Parish School Board	\$ 15,390,000 (3)	100%	\$ 15,390,000
OVERLAPPING:			
Webster Parish Police Jury	2,265,000	100%	2,265,000
City of Minden	6,775,000	100%	6,775,000
	\$ 9,040,000		\$ 9,040,000
	\$ 24,430,000		\$ 24,430,000

Notes:

- (1) Various taxing districts exist within Webster Parish that involve a small percentage of taxpayers. These districts' debt is not included.
- (2) This represents the debt of all the constituents who reside in Webster Parish.
- (3) Excluding amount available for repayment in the debt service funds.

Table 10

WEBSTER PARISH SCHOOL BOARD
Minden, Louisiana

Computation of Legal Debt Margin
June 30, 2003

Assessed Value Before Homestead Exemption	\$	<u>164,021,025</u>
Debt limit fifty percent (35%) of assessed value (1)		57,407,359
Amount of debt applicable to debt limit (2):		
Total general bonded debt	\$	15,390,000
Less: Assets in debt service funds		<u>683,554</u>
Total amount of debt applicable to debt limit		<u>14,706,446</u>
Legal debt margin	\$	<u><u>42,700,913</u></u>

Notes:

- (1) This percentage is in accordance with Act 103 of 1980 Regular Session of the Louisiana Legislature R.S. 39:562(C).
- (2) Includes general obligation bonds only.

WEBSTER PARISH SCHOOL BOARD
Minden, Louisiana

Ratio of Annual Debt Service Expenditures for
General Bonded Debt to Total General Expenditures

Fiscal years ended June 30, 1994 through June 30, 2003

Year Ended June 30,	Debt Service Expenditures Interest and		Total	Total General Expenditures (2)	Ratio of Debt Service to General Expenditures (Percent)
	Principal (1)	Fiscal Charges (1)			
1994	955,290	616,201	1,571,491	34,414,492	4.57%
1995	1,012,000	453,267	1,465,267	33,226,098	4.41%
1996	1,018,000	392,941	1,410,941	33,877,290	4.16%
1997	1,065,000	472,710	1,537,710	38,071,512	4.04%
1998	1,120,000	541,727	1,661,727	43,741,588	3.80%
1999	1,279,000	680,726	1,959,726	44,685,495	4.39%
2000	1,357,000	777,590	2,134,590	52,892,138	4.04%
2001	1,136,000	774,287	1,910,287	46,827,950	4.08%
2002	1,120,000	900,001	2,020,001	50,399,168	4.01%
2003	1,225,000	839,771	2,064,771	55,098,348	3.75%

Notes:

(1) Includes debt service on general obligation bonds only.

(2) Includes general expenditures for General Fund, Special Revenue Funds, Debt Service Funds and Capital Project Funds.

WEBSTER PARISH SCHOOL BOARD
Minden, Louisiana

Demographic Statistics
Last Ten Calendar Years

Calendar Year	Population (1)	School Enrollment	Unemployment Rate (2)	Per Capita Income (1)
1993	41,400	8,151	10.4%	15,085
1994	41,700	8,241	12.9%	15,524
1995	42,200	8,238	11.0%	16,105
1996	42,366	8,352	9.7%	16,502
1997	42,366	8,225	8.9%	N/A
1998	43,631	8,094	8.3%	N/A
1999	43,631	7,764	6.4%	N/A
2000	41,831	7,554	6.2%	N/A
2001	41,989	7,785	4.5%	N/A
2002	41,831	7,782	3.6%	N/A

Notes:

(1) Louisiana Electronic Assistance Program (LEAP) operated by University of Louisiana at Monroe Center for Business and Economic Research (<http://leap.ulm.edu>).

(2) 1992 Research Division, Louisiana Tech; 1993-1998 Louisiana Electronic Assistance Program (LEAP).

N/A - Information not available.

WEBSTER PARISH SCHOOL BOARD
Minden, Louisiana

Property Value, Construction and Bank Deposits
Last Ten Calendar Years

Calendar Year	Property Value (3)		Exemptions	Total	Commercial Construction (1)		Residential Construction (1)		Bank Deposits (2)
	Commercial	Residential			Number of Units	Value	Number of Units	Value	
1993	453,182,100	478,944,000	341,910,767	590,215,333	26	6,832,098	32	2,484,834	318,566,000
1994	420,857,140	485,396,950	351,571,167	554,682,923	37	849,000	12	4,567,000	329,320,000
1995	437,098,087	494,350,150	360,534,500	570,913,737	N/A	2,381,000	8	1,467,000	332,419,000
1996	486,106,293	517,582,350	369,396,300	634,292,343	N/A	7,563,000	475	4,513,000	418,000,000
1997	542,340,293	528,347,550	378,731,633	691,956,210	N/A	1,153,000	116	2,918,000	427,000,000
1998	568,531,140	532,934,050	391,180,967	710,284,223	N/A	11,938,000	117	2,066,000	443,000,000
1999	612,517,647	548,199,350	402,243,100	758,473,897	N/A	5,477,000	97	2,868,000	373,000,000
2000	598,284,673	570,385,350	415,779,867	752,890,156	N/A	N/A	17	1,809,000	470,000,000
2001	635,036,427	587,298,750	427,068,067	795,267,110	N/A	N/A	N/A	N/A	N/A
2002	633,815,013	605,760,450	433,744,333	805,831,130	N/A	N/A	N/A	N/A	N/A

Notes:

(1) Source: City of Minden

(2) Source: University of Louisiana at Monroe, Center for Business & Economic Research and Federal Deposit Insurance Corporation

(3) Source: Webster Parish Tax Assessor

N/A: Information not available

Table 14

WEBSTER PARISH SCHOOL BOARD
Minden, Louisiana

Principal Taxpayers
June 30, 2003

Taxpayers	Type of Business	2002 Assessed Value	Percentage of Total Assessed Valuation
International Paper Co.	Wood Products	\$ 9,499,810	5.79%
Marathon Oil Co	Oil and Gas	4,561,440	2.78%
Entergy Services, Inc.	Electric Utility	4,364,630	2.66%
Coastal Towing, Inc.	Towing Services	4,036,990	2.46%
International Paper Co.	Wood Products	3,637,227	2.22%
Regions Bank	Banking	3,072,600	1.87%
El Paso Corporation	Oil and Gas	2,972,790	1.81%
Bellsouth Telecommunications	Telephone Utility	2,750,940	1.68%
Calumet Lubricants Co.	Manufacturing	2,257,690	1.38%
Dukeenergy Field Services Inc.	Oil and Gas	2,151,610	1.31%
Total for ten principal taxpayers		39,305,727	23.96%
Total for remaining taxpayers		124,715,658	76.04%
Total for all taxpayers		\$ 164,021,385	100.00%

Source: Webster Parish Tax Assessor

WEBSTER PARISH SCHOOL BOARD
Minden, Louisiana

Principal Employers
June 30, 2003

Name of Business	Type of Business
Fibrebond Corporation	Portable Buildings
Minden Medical Center	Health Care
IHS of Minden	Nursing Care
Clement Industries	Trailers
Inland Container	Corrugated Boxes
Ruskin	Industrial Louvers
Town & Country Center	Nursing Care
Reynolds Industrial Contractor's, Inc.	Industrial Welding
McInnis Corporation	Construction
Mister Twister	Fishing Tackle

Source: Louisiana Department of Labor

Table 16

WEBSTER PARISH SCHOOL BOARD
Minden, Louisiana

Attendance Data

Fiscal years ended June 30, 1994 through June 30, 2003

Fiscal Year	Number of Graduates	Average Daily Membership	Average Daily Attendance		School Enrollment
			Amount	Percent of Change	
1994	429	8,405	7,981	2.66%	8,151
1995	386	8,135	7,782	-2.49%	8,241
1996	397	8,304	7,820	0.48%	8,238
1997	397	8,214	7,731	-1.13%	8,352
1998	415	8,025	7,509	-2.87%	8,225
1999	476	7,940	7,574	0.86%	7,958
2000	451	7,867	7,458	-1.53%	7,764
2001	397	7,695	7,250	-2.79%	7,554
2002	359	7,644	7,189	-0.84%	7,782
2003	N/A	N/A	N/A	N/A	7,516

**Webster Parish School Board
Minden, Louisiana**

**Compliance with Single Audit Act Amendment of 1996
For the Year Ended June 30, 2003**

**Webster Parish School Board
Table of Contents**

	<u>Page</u>
OTHER REPORTS REQUIRED BY <u>GOVERNMENT AUDITING STANDARDS AND BY OFFICE OF MANAGEMENT AND BUDGET (OMB) CIRCULAR NO. A-133</u>	
Report on Compliance and on Internal Control Over Financial Reporting Based on an Audit of Financial Statements Performed in Accordance With <u>Government Auditing Standards</u>	1
Report on Compliance With Requirements Applicable to Each Major Program and on Internal Control Over Compliance in Accordance With <u>OMB Circular No. A-133</u>	2-3
Schedule of Expenditures of Federal Awards	4
Notes to the Schedule of Expenditures of Federal Awards	5
Schedule of Findings and Questioned Costs	6
OTHER INFORMATION	
Independent Accountants' Report on Applying Agreed-upon Procedures	7-9
School Board prepared Performance and Statistical Data Schedules	10-19

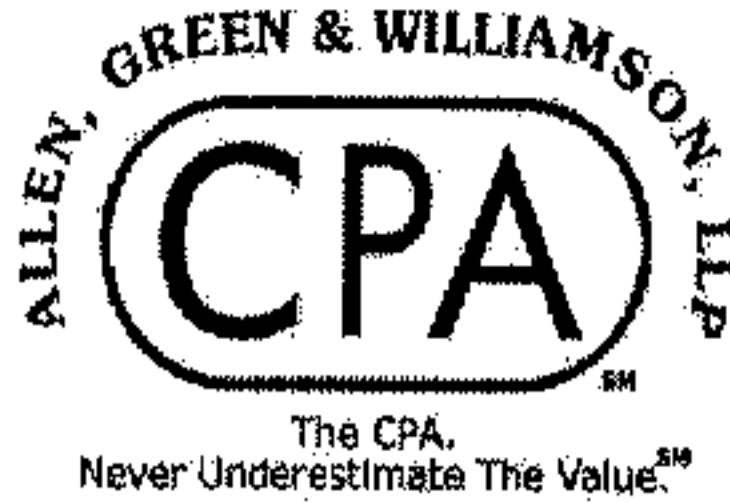

ALLEN, GREEN & WILLIAMSON, LLP

CERTIFIED PUBLIC ACCOUNTANTS

P. O. Box 6075

Monroe, LA 71211-6075

2414 Ferrand Street
Monroe, LA 71201

Phone: (318) 388-4422

Fax: (318) 388-4664

Toll-free: (888) 741-0205
www.allengreencpa.com

Tim Green, CPA

Margie Williamson, CPA

Ernest L. Allen, CPA
(Retired)
1963 - 2000

Report on Compliance and on Internal Control Over Financial Reporting Based on an Audit of Financial Statements Performed in Accordance With Government Auditing Standards

Board Members
Webster Parish School Board
Minden, Louisiana

We have audited the financial statements of Webster Parish School Board as of and for the year ended June 30, 2003, and have issued our report thereon dated December 5, 2003. We conducted our audit in accordance with auditing standards generally accepted in the United States of America and the standards applicable to financial audits contained in Government Auditing Standards, issued by the Comptroller General of the United States of America.

Compliance

As part of obtaining reasonable assurance about whether the School Board's financial statements are free of material misstatement, we performed tests of its compliance with certain provisions of laws, regulations, contracts and grants, noncompliance with which could have a direct and material effect on the determination of financial statement amounts. However, providing an opinion on compliance with those provisions was not an objective of our audit and, accordingly, we do not express such an opinion. The results of our tests disclosed no instance of noncompliance that is required to be reported under Government Auditing Standards.

Internal Control Over Financial Reporting

In planning and performing our audit, we considered the School Board's internal control over financial reporting in order to determine our auditing procedures for the purpose of expressing our opinion on the basic financial statements and not to provide assurance on internal control over financial reporting. Our consideration of internal control over financial reporting would not necessarily disclose all matters in internal control over financial reporting that might be material weaknesses. A material weakness is a condition in which the design or operation of one or more of internal control components does not reduce to a relatively low level the risk that misstatements in amounts that would be material in relation to the basic financial statements being audited may occur and not be detected within a timely period by employees in the normal course of performing their assigned functions. We noted no matters involving internal control over financial reporting and its operation that we consider to be material weaknesses.

This report is intended solely for the information and use of the Board, management, federal awarding agencies, and pass-through entities and is not intended to be and should not be used by anyone other than these specified parties.

Allen, Green + Williamson, LLP

ALLEN, GREEN & WILLIAMSON, LLP

Monroe, Louisiana
December 5, 2003

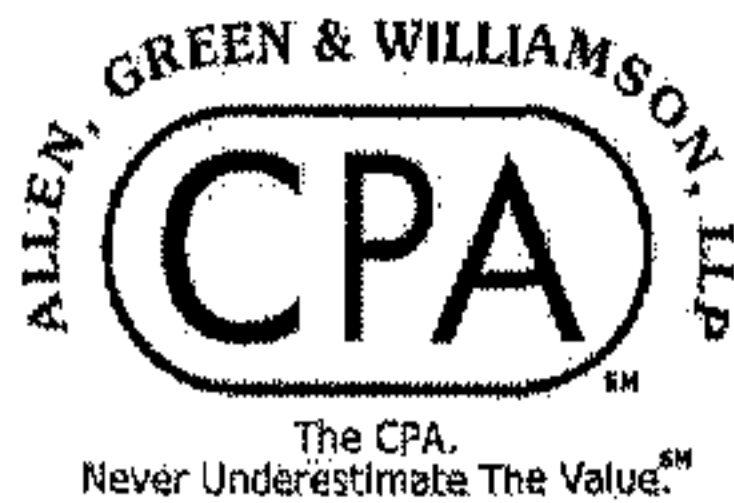

ALLEN, GREEN & WILLIAMSON, LLP

CERTIFIED PUBLIC ACCOUNTANTS

P. O. Box 6075

Monroe, LA 71211-6075

2414 Ferrand Street
Monroe, LA 71201

Phone: (318) 388-4422

Fax: (318) 388-4664

Toll-free: (888) 741-0205
www.allengreencpa.com

Tim Green, CPA

Margie Williamson, CPA

Ernest L. Allen, CPA
(Retired)
1963 – 2000

Report on Compliance With Requirements Applicable to Each Major Program and on Internal Control Over Compliance in Accordance With OMB Circular No. A-133

Board Members
Webster Parish School Board
Minden, Louisiana

Compliance

We have audited the compliance of the Webster Parish School Board with the types of compliance requirements described in the U. S. Office of Management and Budget (OMB) Circular No. A-133 Compliance Supplement that are applicable to each of its major federal programs for the year ended June 30, 2003. The School Board's major federal programs are identified in the summary of auditors' results section of the accompanying Schedule of Findings and Questioned Costs. Compliance with the requirements of laws, regulations, contracts, and grants applicable to each of its major federal programs is the responsibility of the School Board's management. Our responsibility is to express an opinion on the School Board's compliance based on our audit.

We conducted our audit of compliance in accordance with auditing standards generally accepted in the United States of America; the standards applicable to financial audits contained in Government Auditing Standards, issued by the Comptroller General of the United States of America; and OMB Circular No. A-133, Audits of States, Local Governments, and Non-Profit Organizations. Those standards and OMB Circular No. A-133 require that we plan and perform the audit to obtain reasonable assurance about whether noncompliance with the types of compliance requirements referred to above that could have a direct and material effect on a major federal program occurred. An audit includes examining, on a test basis, evidence about the School Board's compliance with those requirements and performing such other procedures as we considered necessary in the circumstances. We believe that our audit provides a reasonable basis for our opinion. Our audit does not provide a legal determination on the School Board's compliance with those requirements.

In our opinion, the School Board complied, in all material respects, with the requirements referred to above that are applicable to each of its major federal programs for the year ended June 30, 2003.

Internal Control Over Compliance

The management of the School Board is responsible for establishing and maintaining effective internal control over compliance with requirements of laws, regulations, contracts and grants applicable to federal programs. In planning and performing our audit, we considered the School Board's internal control over compliance with requirements that could have a direct and material effect on a major federal program in order to determine our auditing procedures for the purpose of expressing our opinion on compliance and to test and report on internal control over compliance in accordance with OMB Circular No. A-133.

Our consideration of the internal control over compliance would not necessarily disclose all matters in the internal control that might be material weaknesses. A material weakness is a condition in which the design or operation of one or more of the internal control components does not reduce to a relatively low level the risk that noncompliance with applicable requirements of laws, regulations, contracts and grants that would be material in relation to a major federal program being audited may occur and not be detected within a timely period by employees in the normal course of performing their assigned functions. We noted no matters involving the internal control over compliance and its operation that we consider to be material weaknesses.

Schedule of Expenditures of Federal Awards

We have audited the basic financial statements of Webster Parish School Board as of and for the year ended June 30, 2003, and have issued our report thereon dated December 5, 2003. Our audit was performed for the purpose of forming an opinion on the basic financial statements taken as a whole. The accompanying Schedule of Expenditures of Federal Awards is presented for purposes of additional analysis as required by OMB Circular No. A-133 and is not a required part of the basic financial statements. Such information has been subjected to the auditing procedures applied in the audit of the basic financial statements and, in our opinion, is fairly stated, in all material respects, in relation to the basic financial statements taken as a whole.

This report is intended solely for the information and use of the Board, management, federal awarding agencies, and pass-through entities and is not intended to be and should not be used by anyone other than these specified parties.

Allen, Green + Williamson, LLP

ALLEN, GREEN & WILLIAMSON, LLP

Monroe, Louisiana

December 5, 2003

Webster Parish School Board
Schedule of Expenditures of Federal Awards
For the Year Ended June 30, 2003

FEDERAL GRANTOR/ PASS-THROUGH GRANTOR/PROGRAM NAME	<u>Number</u>	<u>CFDA Grantor No.</u>	<u>Pass-Through Expenditures</u>
United States Department of Agriculture			
Passed Through Louisiana Department of Agriculture and Forestry:			
Food Distribution (Commodities)	10.550	N/A	\$ 229,230
Passed Through Louisiana Department of Education:			
School Breakfast Program	10.553	N/A	477,944
National School Lunch Program	10.555	N/A	1,342,621
Passed Through Louisiana Department of Treasury:			
Schools and Roads - Grants to States (National Forest Lands)	10.665	N/A	<u>156,153</u>
Total United States Department of Agriculture			<u>2,205,948</u>
United States Department of Education			
Passed Through Louisiana Department of Education:			
Adult Education - State Grant Program	84.002	N/A	58,832
Title I Grants to Local Educational Agencies	84.010	03-IASA-60-I	2,033,008
Special Education:			
Grants to States (Part B)	84.027	03FT60	922,685
Preschool Grants	84.173	03PF60	31,664
Vocational Education:			
Basic Grants to States	84.048	N/A	116,721
Innovative Education Program Strategies -			
Title VI (formerly Chapter 2)	84.298	03-IASA-60-VI	49,197
Title II (Improving Teacher Quality State Grants)	84.367	N/A	597,025
Title IV (Safe and Drug-Free Schools - State Grant)	84.186	03-IASA-60-IV	55,284
Technology Literacy Challenge	84.318X	03-LCF-60-F	270,319
Comprehensive School Reform Demonstration	84.332	02-TG-60-C	255,071
Technology Innovative Challenge	84.303		<u>42,356</u>
Total United States Department of Education			<u>4,432,162</u>
United States Department of Health and Human Services			
Passed Through the Louisiana Department of Education:			
TANF	93.558	N/A	175,434
Child Care and Development Block Grant (Starting Points Preschool)	93.575	N/A	<u>61,036</u>
Total United States Department of Health and Human Services			236,470
United States Department of Labor			
Passed Through the Coordinating and Development Council			
of Shreveport - Workforce Investment Act	17.259	N/A	<u>244,000</u>
United States Department of Defense			
Direct Programs:			
Flood Control Projects	12.106	N/A	<u>4,753</u>
TOTAL FEDERAL AWARDS			<u><u>\$7,123,333</u></u>

Webster Parish School Board
Notes to the Schedule of Expenditures of Federal Awards
For the Year Ended June 30, 2003

NOTE 1 - GENERAL The accompanying Schedule of Expenditures of Federal Awards presents the activity of all federal awards programs of the Webster Parish School Board. The School Board reporting entity is defined in Note 1 to the School Board's basic financial statements. Federal awards received directly from federal agencies, as well as federal awards passed through other government agencies, are included on the schedule.

NOTE 2 - BASIS OF ACCOUNTING The accompanying Schedule of Expenditures of Federal Awards is presented using the modified accrual basis of accounting, which is described in Note 1 to the School Board's basic financial statements.

NOTE 3 - RELATIONSHIP TO BASIC FINANCIAL STATEMENTS Federal awards revenues are reported in the School Board's basic financial statements as follows:

	<u>Federal Sources</u>	
General Fund		\$ 160,906
Special Revenue Funds:		
Title I		2,033,008
Other ESEA Funds:		
Title VI	49,197	
Title II	597,025	
Title IV	55,284	
Class-Size Reduction		701,506
Special Education:		
State Grants	922,685	
Preschool Grants	31,664	954,349
Special Federal Funds:		
Vocational Education	116,721	
Adult Education	58,832	
WIA	244,000	
TANF	175,434	
Starting Points Preschool	61,036	656,023
School Food Service:		
School Lunch	1,342,621	
School Breakfast	477,944	
Commodities	229,230	2,049,795
Technology Literacy Challenge		312,675
Comprehensive School Reform		<u>255,071</u>
		<u>\$7,123,333</u>

NOTE 4 - RELATIONSHIP TO FEDERAL FINANCIAL REPORTS Amounts reported in the accompanying schedule agree with the amounts reported in the related federal financial reports except for changes made to reflect amounts in accordance with accounting principles generally accepted in the United States of America.

NOTE 5 - MATCHING REVENUES For those funds that have matching revenues and state funding, federal expenditures were determined by deducting matching revenues from total expenditures.

NOTE 6 - NONCASH PROGRAMS The commodities received, which are noncash revenues, are valued using prices provided by the United States Department of Agriculture.

Webster Parish School Board
Schedule of Findings and Questioned Costs
For the Year Ended June 30, 2003

PART I - Summary of the Auditors' Results

Financial Statement Audit

- i. The type of audit report issued was unqualified.
- ii. There were no reportable conditions required to be disclosed by Government Auditing Standards issued by the Comptroller General of the United States of America.
- iii. There was no instance of noncompliance considered material, as defined by Government Auditing Standards, to the financial statement.

Audit of Federal Awards

- iv. There were no reportable conditions required to be disclosed by OMB Circular No. A-133.
- v. The type of report the auditor issued on compliance for major programs was unqualified.
- vi. The audit disclosed no audit findings which the auditor is required to report under OMB Circular No. A-133, Section .510(a).
- vii. The major federal programs are:
 - CFDA #84.010 Title I Grants to Local Educational Agencies
 - CFDA #84.367 Improving Teacher Quality State Grants (Title II)
- viii. The dollar threshold used to distinguish between Type A and Type B programs as described in OMB Circular No. A-133, Section .520(b) was \$300,000.
- ix. The auditee does qualify as a low-risk auditee under OMB Circular No. A-133, Section .530.

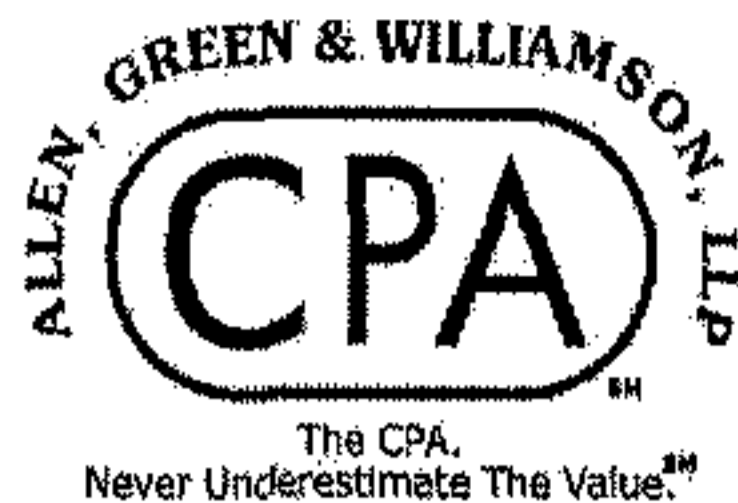

ALLEN, GREEN & WILLIAMSON, LLP

CERTIFIED PUBLIC ACCOUNTANTS

P. O. Box 6075

Monroe, LA 71211-6075

2414 Ferrand Street
Monroe, LA 71201

Phone: (318) 388-4422
Fax: (318) 388-4664

Toll-free: (888) 741-0205
www.allengreencpa.com

Tim Green, CPA

Margie Williamson, CPA

Ernest L. Allen, CPA
(Retired)
1963 – 2000

INDEPENDENT ACCOUNTANTS' REPORT ON APPLYING AGREED-UPON PROCEDURES

Board Members
Webster Parish School Board
Minden, Louisiana

We have performed the procedures included in the *Louisiana Governmental Audit Guide* and enumerated below, which were agreed to by the management of the Webster Parish School Board, Minden, Louisiana, and the Legislative Auditor, State of Louisiana, solely to assist users in evaluating management's assertions about the performance and statistical data accompanying the annual financial statements of the School Board and to determine whether the specified schedules are free of obvious errors and omissions as provided by the Board of Elementary and Secondary Education (BESE). This agreed-upon procedures engagement was performed in accordance with standards established by the American Institute of Certified Public Accountants and applicable standards of *Government Auditing Standards*. The sufficiency of these procedures is solely the responsibility of the specified users of the reports. Consequently, we make no representation regarding the sufficiency of the procedures described below either for the purpose for which this report has been requested or for any other purpose.

Our procedures and findings relate to the accompanying schedules of supplemental information and are as follows:

General Fund Instructional and Support Expenditures and Certain Local Revenue Sources (Schedule 1)

1. We selected a random sample of 25 transactions and reviewed supporting documentation to determine if the sampled expenditures/revenues are classified correctly and are reported in the proper amounts for each of the following amounts reported on the schedule:
 - Total General Fund Instructional Expenditures,
 - Total General Fund Equipment Expenditures,
 - Total Local Taxation Revenue,
 - Total Local Earnings on Investment in Real Property,
 - Total State Revenue in Lieu of Taxes,
 - Nonpublic Textbook Revenue, and
 - Nonpublic Transportation Revenue.

Comment: No exceptions were noted as a result of applying agreed-upon procedures.

Education Levels of Public School Staff (Schedule 2)

2. We reconciled the total number of full-time classroom teachers per the schedule "Experience of Public Principals and Full-time Classroom Teachers" (Schedule 4) to the combined total number of full-time classroom teachers per this schedule and to school board supporting payroll records as of October 1.

Comment: No exceptions were noted as a result of applying agreed-upon procedures.

3. We reconciled the combined total of principals and assistant principals per the schedule "Experience of Public Principals and Full-time Classroom Teachers" (Schedule 4) to the combined total of principals and assistant principals per this schedule.

Comment: No exceptions were noted as a result of applying agreed-upon procedures.

4. We obtained a list of full-time teachers, principals, and assistant principals by classification as of October 1 and as reported on the schedule. We traced a random sample of 25 teachers to the individual's personnel file and determine if the individual's education level was properly classified on the schedule.

Comment: No exceptions were noted as a result of applying agreed-upon procedures.

Number and Type of Public Schools (Schedule 3)

5. We obtained a list of schools by type as reported on the schedule. We compared the list to the schools and grade levels as reported on the Title I Grants to Local Educational Agencies (CFDA 84.010) application and/or the National School Lunch Program (CFDA 10.555)

Comment: No exceptions were noted as a result of applying agreed-upon procedures.

Experience of Public Principals and Full-time Classroom Teachers (Schedule 4)

6. We obtained a list of full-time teachers, principals, and assistant principals by classification as of October reported on the schedule and traced the same sample used in procedure 4 to the individual's personnel file and determined if the individual's experience was properly classified on the schedule.

Comment: No exceptions were noted as a result of applying agreed-upon procedures.

Public Staff Data (Schedule 5)

7. We obtained a list of all classroom teachers including their base salary, extra compensation, and ROTC or rehired retiree status as well as full-time equivalent (FTE) as reported on the schedule and traced a random sample of 25 teachers to the individual's personnel file and determined if the individual's salary, extra compensation, and full-time equivalents were properly included on the schedule.

Comment: We found two instances where there was a variance between base salary and other compensation. In one instance other compensation was overstated by \$54 and in the other instance other compensation was understated by \$292. This in turn caused base salary to be understated or overstated by the same amount.

Management's Response: When we compared each employee's file to that reported on the PEP report we found a difference of three to six dollars. It appears that our software rounded up on several of the salary components for those employees cited in the report. We plan to have our programmer review the software and make appropriate modifications to assure this doesn't happen again.

8. We recalculated the average salaries and full-time equivalents reported in the schedule.

Comment: Our recalculation yielded FTEs of \$504.03 and \$486.52 for all classroom teachers and the exclusion of retirees and ROTC teachers, respectively. This, in turn, caused our averages to be \$36,621 for all classroom instructors, and \$37,238 for all classroom instructors excluding other compensation. The averages after exclusion of retirees and ROTC were \$37,470 for all remaining instructors and \$37,001 for these instructors excluding other compensation.

Management's Response: We accept the findings as reported by the auditor. Apparently there is a difference in data reported to PEP and the data compiled by us to calculate the average salaries. We will continue to work on reconciling the differences and modifying our software to assure true comparisons.

Class Size Characteristics Schedule 6)

9. We obtained a list of classes by school, school type, and class size as reported on the schedule and reconciled school type classifications to Schedule 3 data, as obtained in procedure 5. We then traced a random sample of 10 classes to the October 1 roll books for those classes and determined if the class was properly classified on the schedule.

Comment: No exceptions were noted as a result of applying agreed-upon procedures.

Louisiana Educational Assessment Program (LEAP) for the 21st century (Schedule 7)

10. We obtained test scores as provided by the testing authority and reconciled scores as reported by the testing authority to scores reported in the schedule by the School Board.

Comment: No exceptions were noted as a result of applying agreed-upon procedures.

The Graduation Exit Exam for the 21st Century(Schedule 8)

11. We obtained test scores as provided by the testing authority and reconciled scores as reported by the testing authority to scores reported in the schedule by the School Board.

Comment: No exceptions were noted as a result of applying agreed-upon procedures.

The Iowa Tests(Schedule 9)

12. We obtained test scores as provided by the testing authority and reconciled scores as reported by the testing authority to scores reported in the schedule by the School Board.

Comment: No exceptions were noted as a result of applying agreed-upon procedures.

We were not engaged to, and did not, perform an examination, the objective of which would be the expression of an opinion on management's assertions. Accordingly, we do not express such an opinion. Had we performed additional procedures, other matters might have come to our attention that would have been reported to you.

This report is intended solely for the use of management of the Webster Parish School Board, the Louisiana Department of Education, the Louisiana Legislature, and the Legislative Auditor, State of Louisiana, and should not be used by those who have not agreed to the procedures and taken responsibility for the sufficiency of the procedures for their purposes. Under Louisiana Revised Statute 24:513, this report is distributed by the Legislative Auditor as a public document.

Allen, Green + Williamson, LLP

ALLEN, GREEN & WILLIAMSON, LLP

Monroe, Louisiana
October 7, 2003

**WEBSTER PARISH SCHOOL BOARD
MINDEN, LOUISIANA**

**GENERAL FUND INSTRUCTINAL AND SUPPORT EXPENDITURES
AND CERTAIN LOCAL REVENUE SOURCES
FOR THE YEAR ENDED JUNE 30, 2003**

GENERAL FUND INSTRUCTIONAL AND EQUIPMENT EXPENDITURES

CLASSROOM TEACHER SALARIES	\$	16,161,536	
OTHER INSTRUCTIONAL STAFF ACTIVITIES	\$	1,502,472	
EMPLOYEES BENEFITS	\$	5,133,787	
PURCHASED PROFESSIONAL AND TECHNICAL SERVICES	\$	411,480	
INSTRUCTIONAL MATERIALS & SUPPLIES	\$	810,611	
INSTRUCTIONAL EQUIPMENT	\$	99,581	
TOTAL TEACHER AND STUDENT INTERACTION ACTIVITIES			\$ 24,119,467
OTHER INSTRUCTIONAL ACTIVITIES		0	\$ 78,098
PUPIL SUPPORT ACTIVITIES	\$	1,444,157	
LESS: EQUIPMENT FOR PUPIL SUPPORT ACTIVITIES	\$	-	
NET PUPIL SUPPORT ACTIVITIES			\$ 1,444,157
INSTRUCTIONAL STAFF SERVICES	\$	1,697,576.00	
LESS: EQUIPMENT FOR INSTRUCTIONAL STAFF SERVICES	\$	-	
NET INSTRUCTIONAL STAFF SERVICES			\$ 1,697,576
TOTAL GENERAL FUND INSTRUCTIONAL EXPENDITURES			<u>\$ 27,339,298</u>
TOTAL GENERAL FUND EQUIPMENT EXPENDITURES			<u>\$ 99,581</u>

CERTAIN LOCAL REVENUE SOURCES

LOCAL TAXATION REVENUE:			
CONSTITUTIONAL AD VALOREM TAXES	\$	688,836	
RENEWABLE AD VALOREM TAX	\$	2,201,814	
DEBT SERVICE AD VALOREM TAX	\$	1,752,261	
UP TO 1% OF COLLECTIONS BY SHERIFF ON TAXES OTHER THAN SCHOOL TAXES	\$	113,266	
SALES AND USE TAXES	\$	-	
TOTAL LOCAL TAXATION REVENUE			<u>\$ 4,756,177</u>
LOCAL EARNINGS ON INVESTMENT IN REAL PROPERTY:			
EARNINGS FROM 16TH SECTION PROPERTY	\$	-	
EARNINGS FROM OTHER REAL PROPERTY	\$	-	
TOTAL LOCAL EARNINGS ON INVESTMENT IN REAL PROPERTY			<u>\$ -</u>
STATE REVENUE IN LIEU OF TAXES:			
REVENUE SHARING-CONSTITUTIONAL TAX	\$	114,966	
REVENUE SHARING-OTHER TAXES	\$	258,084	
REVENUE SHARING-EXCESS PORTION	\$	-	
OTHER REVENUE IN LIEU OF TAXES			
TOTAL STATE REVENUE IN LIEU OF TAXES			<u>\$ 373,050</u>
NONPUBLIC TEXTBOOK REVENUE			<u>\$ 10,646</u>
NONPUBLIC TRANSPORTATION REVENUE			<u>\$ -</u>

Schedule 2

WEBSTER PARISH SCHOOL BOARD
MINDEN, LOUISIANA

Education Levels of Public School Staff
As of October 1, 2002

Category	Full-time Classroom Teachers				Principals & Assistant Principals			
	Certificated		Uncertificated		Certificated		Uncertificated	
	Number	Percent	Number	Percent	Number	Percent	Number	Percent
Less than a Bachelor's Degree								
Bachelor's Degree	332	65.48%	0	#DIV/0!	0	0.00%	0	0.00%
Master's Degree	102	20.12%	0	#DIV/0!	4	15.38%	0	0.00%
Master's Degree + 30	69	13.61%	0	#DIV/0!	21	80.77%	0	0.00%
Specialist in Education	3	0.59%	0	#DIV/0!	1	3.85%	0	0.00%
Ph. D. or Ed. D.	1	0.20%	0	#DIV/0!	0	0.00%	0	0.00%
Total	507	100.00%	0	#DIV/0!	26	100%	0%	0%

**WEBSTER PARISH SCHOOL BOARD
MINDEN, LOUISIANA**

**Number and Type of Public Schools
For the Year Ended June 30, 2003**

Type	Number
Elementary	10
Middle/Jr. High	3
Secondary	5
Combination	3
Total	21

Note: Schools opened or closed during the fiscal year are included in this schedule.

LAKESIDE JR. HIGH AND LAKESIDE HIGH SCHOOL CONSOLIDATED INTO ONE SCHOOL
FOR THE 2003-2004 SCHOOL YEAR

**WEBSTER PARISH SCHOOL BOARD
MINDEN, LOUISIANA**

**Experience of Public Principals and Full-time Classroom Teachers
As of October 1, 2002**

	0-1 Yr.	2-3 Yrs.	4-10 Yrs.	11-14 Yrs.	15-19 Yrs.	20-24 Yrs.	25+ Yrs.	Total
Assistant Principals	0	0	1	0	0	0	3	4
Principals	0	0	1	1	1	6	13	22
Classroom Teachers	42	50	151	47	50	59	108	507
Total	42	50	153	48	51	65	124	533

Schedule 5

**WEBSTER PARISH SCHOOL BOARD
MINDEN, LOUISIANA**

**Public School Staff Data
For the Year Ended June 30, 2003**

	Classroom Teachers Excluding ROTC and Rehired Retirees	
	All Classroom Teachers	
Average Classroom Teachers' Salary Including Extra Compensation	\$ 37,517	\$ 37,353
Average Classroom Teachers' Salary Excluding Extra Compensation	\$ 37,059	\$ 36,881
Number of Teacher Full-time Equivalents (FTEs) used in Computation of Average Salaries	507.69	492.58

Note: Figures reported include all sources of funding (i.e., federal, state, and local) but exclude employee benefits. Generally, retired teachers rehired to teach receive less compensation than non-retired teachers and ROTC teachers receive more compens

**WEBSTER PARISH SCHOOL BOARD
MINDEN, LOUISIANA**

**Class Size Characteristics
As of October 1, 2002**

School Type	Class Size Range							
	1 - 20		21 - 26		27 - 33		34+	
	Percent	Number	Percent	Number	Percent	Number	Percent	Number
Elementary	39.02%	231	49.83%	295	11.15%	66	0.00%	0
Elementary Activity Classes	12.79%	11	38.37%	33	23.26%	20	25.58%	22
Middle/Jr. High	38.89%	21	61.11%	33	0.00%	0	0.00%	0
Middle/Jr. High Activity Classes	100.00%	11	0.00%	0	0.00%	0	0.00%	0
High	42.16%	172	25.74%	105	32.11%	131	0.00%	0
High Activity Classes	58.82%	40	17.65%	12	16.18%	11	7.35%	5
Combination	68.01%	236	15.56%	54	16.43%	57	0.00%	0
Combination Activity Classes	45.28%	24	18.87%	10	26.42%	14	9.43%	5

Note: The Board of Elementary and Secondary Education has set specific limits on the maximum size of classes at various grade levels. The maximum enrollment in grades K-3 is 26 students and maximum enrollment in grades 4-12 is 33 students. These limits

**WEBSTER PARISH SCHOOL BOARD
MINDEN, LOUISIANA**

SCHEDULE 7

**Louisiana Educational Assessment Program (LEAP) for the 21st Century
For the Year Ended June 30, 2003**

District Achievement Level Results	English Language Arts						Mathematics						
	2003		2002		2001		2003		2002		2001		
	Number	Percent	Number	Percent	Number	Percent	Number	Percent	Number	Percent	Number	Percent	
Grade 4													
Advanced	2	0%	14	2%	4	1%	14	2%	5	1%	4	1%	
Proficient	67	12%	110	19%	98	16%	75	13%	50	8%	75	12%	
Basic	266	47%	231	39%	284	46%	234	42%	243	41%	228	37%	
Approaching Basic	160	28%	159	27%	151	24%	142	25%	147	25%	154	25%	
Unsatisfactory	68	12%	78	13%	80	13%	98	17%	146	25%	156	25%	
Total	563	100%	592	100.0%	617	100%	563	100%	591	100%	617	100%	

District Achievement Level Results	Science						Social Studies					
	2003		2002		2001		2003		2002		2001	
	Number	Percent	Number	Percent	Number	Percent	Number	Percent	Number	Percent	Number	Percent
Grade 4												
Advanced	7	1%	15	3%	7	1%	3	1%	3	1%	2	0%
Proficient	59	11%	60	10%	59	10%	55	10%	42	7%	70	11%
Basic	233	42%	263	45%	274	44%	274	49%	274	47%	296	48%
Approaching Basic	203	36%	176	30%	215	35%	163	29%	159	27%	142	23%
Unsatisfactory	59	11%	77	13%	62	10%	66	12%	111	19%	107	17%
Total	561	100%	591	100%	617	100%	561	100%	589	100%	617	100%

**WEBSTER PARISH SCHOOL BOARD
MINDEN, LOUISIANA**

**The Graduation Exit Exam for the 21st Century
For the Year Ended June 30, 2003**

SCHEDULE 7

District Achievement Level Results	English Language Arts						Mathematics						
	2003		2002		2001		2003		2002		2001		
	Number	Percent	Number	Percent	Number	Percent	Number	Percent	Number	Percent	Number	Percent	
Grade 8													
Advanced	5	1%	9	1%	2	0%	9	1%	3	0%	4	1%	
Proficient	75	12%	79	12%	61	11%	22	3%	16	2%	24	4%	
Basic	239	37%	166	26%	227	40%	269	38%	228	34%	236	38%	
Approaching Basic	222	34%	293	46%	199	35%	168	24%	215	32%	159	26%	
Unsatisfactory	109	17%	91	14%	84	15%	237	34%	207	31%	199	32%	
Total	650	100%	638	100.0%	573	100%	705	100%	669	100%	622	100%	

District Achievement Level Results	Science						Social Studies					
	2003		2002		2001		2003		2002		2001	
	Number	Percent	Number	Percent	Number	Percent	Number	Percent	Number	Percent	Number	Percent
Grade 8												
Advanced	1	0%	9	1%	4	1%	1	0%	4	1%	4	1%
Proficient	68	11%	73	12%	68	12%	34	5%	49	8%	53	9%
Basic	226	35%	208	34%	225	40%	253	40%	240	39%	249	44%
Approaching Basic	196	31%	191	31%	166	29%	196	31%	182	30%	136	24%
Unsatisfactory	151	24%	130	21%	101	18%	156	24%	134	22%	122	22%
Total	642	100%	611	100.0%	564	100%	640	100%	609	100%	564	100%

**WEBSTER PARISH SCHOOL BOARD
MINDEN, LOUISIANA**

**The Graduation Exit Exam for the 21st Century
For the Year Ended June 30, 2003**

SCHEDULE 8

District Achievement Level Results	English Language Arts						Mathematics					
	2003		2002		2001		2003		2002		2001	
	Number	Percent	Number	Percent	Number	Percent	Number	Percent	Number	Percent	Number	Percent
Grade 10												
Advanced	0	0%	8	1%	3	1%	33	6%	28	5%	15	3%
Proficient	45	8%	51	9%	54	10%	65	11%	51	8%	64	12%
Basic	203	38%	230	41%	231	42%	180	31%	210	34%	183	34%
Approaching Basic	148	28%	131	23%	121	22%	107	18%	99	16%	86	16%
Unsatisfactory	136	26%	147	26%	138	25%	194	34%	229	37%	196	36%
Total	532	100%	567	100.0%	547	100%	579	100%	617	100%	544	100%

District Achievement Level Results	Science						Social Studies					
	2003		2002		2001		2003		2002		2001	
	Number	Percent	Number	Percent	Number	Percent	Number	Percent	Number	Percent	Number	Percent
Grade 11												
Advanced	9	2%	10	2%			7	2%	1	0%		
Proficient	44	10%	54	12%			35	8%	34	7%		
Basic	168	38%	179	39%			213	48%	185	40%		
Approaching Basic	116	26%	88	19%			112	25%	119	26%		
Unsatisfactory	104	24%	132	29%			73	17%	122	26%		
Total	441	100%	463	100.0%			440	100%	461	100%		

**WEBSTER PARISH SCHOOL BOARD
MINDEN, LOUISIANA**

**The IOWA Tests
For the Year Ended June 30, 2003**

	Composite		
	2003	2002	2001
Test of Basic Skills (ITBS)			
Grade 3	56	51	51
Grade 5	55	53	53
Grade 6	53	55	47
Grade 7	48	46	45
Tests of Educational Development (ITED)			
Grade 9	47	47	48

Scores are reported by National Percentile Rank. A student's National Percentile Rank shows the student's relative position or rank as compared to a large, representative sample of students in the same grade from the entire nation. A student with a scor